

INSTALLATION GUIDE

AMP RESEARCH Power Step

MADE IN USA

APPLICATION	MODEL YR	AMP PART #
Dodge Ram Quad Cab 1500	2002 - 2008	75101-01A
Dodge Ram Quad Cab 2500/3500	2003 - 2009	75101-01A
Dodge Ram Mega Cab	2006 - 2009	75118-01A

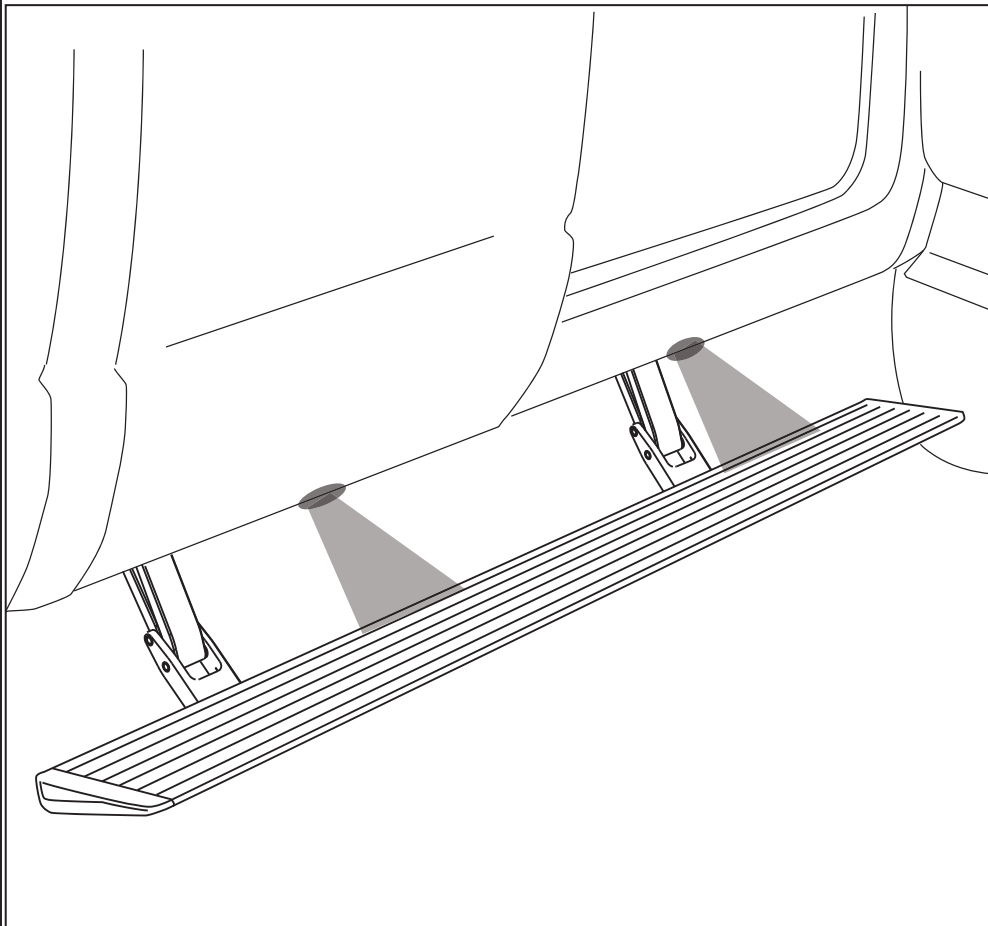

INSTALLATION TIME
3-5 Hours
 Professional installation recommended

SKILL LEVEL

① ② ③ ④

4= Experienced

- TOOLS REQUIRED**
- Safety goggles
 - Measuring tape
 - Flat blade screwdriver
 - Phillips head screwdriver
 - Right angle drill
 - 1/8" drill bit
 - 13 mm socket
 - Ratchet wrench and extension
 - Soldering iron
 - Wire crimpers
 - Wire stripper / cutter
 - Corrosion inhibitor
 - 3/16" hex key wrench (allen wrench)
 - 1/8" hex key wrench (allen wrench)
 - 4 mm hex key wrench (allen wrench)
 - Pop rivet tool
 - Electrical tape

WARRANTY
5-Year Limited Warranty

AMP RESEARCH TECH SUPPORT 1-888-983-2204 (Press 2) Monday - Friday, 7:00 AM - 5:00 PM PST

Invented, engineered and manufactured exclusively by AMP Research in the USA. May be covered by one of the following patents: 6,641,158; 6,830,257; 6,834,875; 6,938,909; 7,055,839; 7,380,807; 7,398,985; 7,584,975 ©2012 AMP Research. All rights reserved. Printed in USA.

INSTALLATION GUIDE

Attaching motor to linkage assembly

The motors need to be installed before continuing with the rest of the Power Step install.

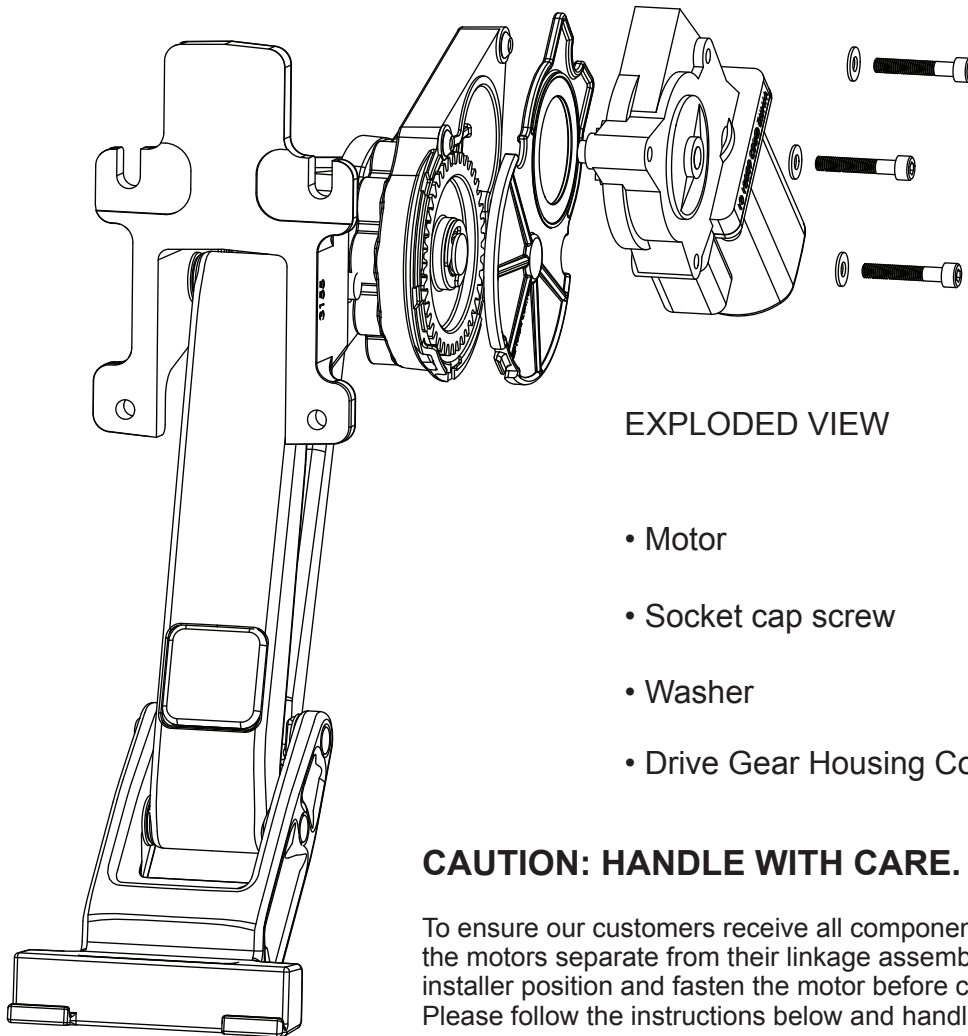

EXPLODED VIEW

- Motor
- Socket cap screw
- Washer
- Drive Gear Housing Cover

CAUTION: HANDLE WITH CARE.

To ensure our customers receive all components with full integrity, we pack the motors separate from their linkage assemblies. This requires that the installer position and fasten the motor before continuing with the install. Please follow the instructions below and handle the assembly carefully.

CAUTION: Dropping the assembly or any excessive impact MAY cause damage to the motor.

Instructions:

1. Position the gear cover in place as shown if not already in place.
2. Seat motor into position on the three mounting bosses. This may require an adjustment of the gear by moving the swing arms.
3. After seating into place, fasten the motor with the three motor mount screws with 4mm Hex Head. Tighten screws to 36 in-lbs (4N-m). **Do not over torque.**

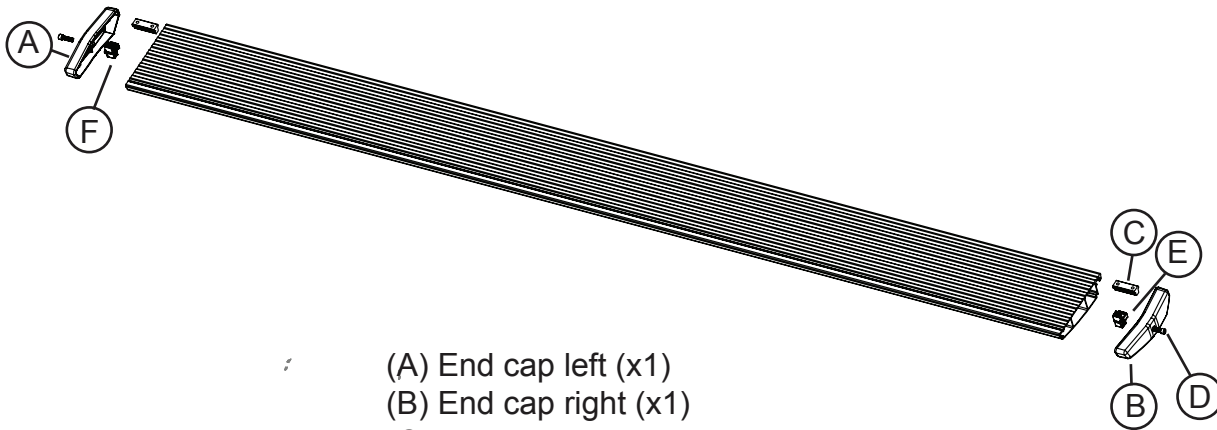

- (A) End cap left (x1)
- (B) End cap right (x1)
- (C) T-nut insert (x2)
- (D) Socket cap screw (x2)
- (E) End cap wedge right (x1)
- (F) End cap wedge left (x1)

1 x2

Running board assembly

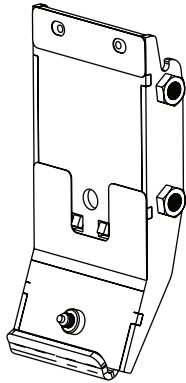

2 x2

Front Bracket

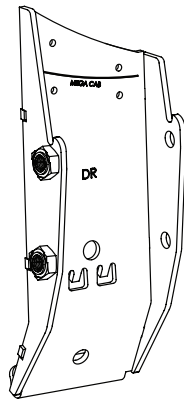

DRIVER REAR BRACKET

3

Driver Rear Bracket

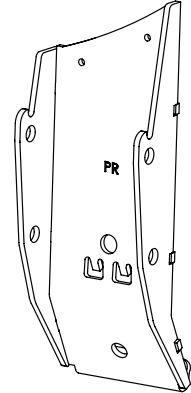

PASSENGER REAR BRACKET

4

Passenger Rear Bracket



5 x2

Idler Linkage

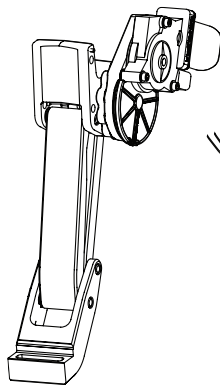

6 x2

Motor Linkage

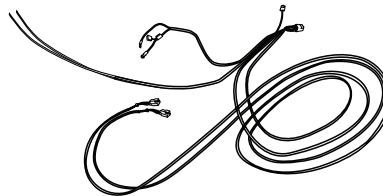

7

Wire Harness

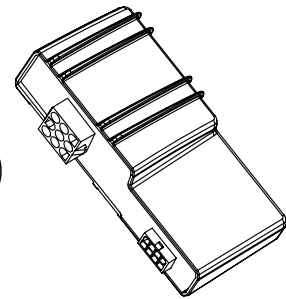

8

Controller STA

PARTS LIST AND
HARDWARE
IDENTIFICATION

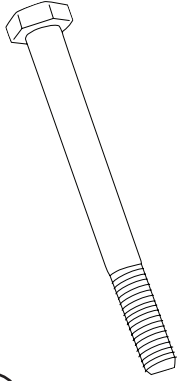

9 x8
Hex Bolt

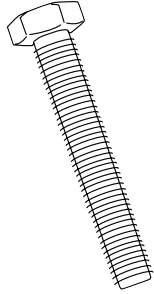

10 x4
Hex Bolt

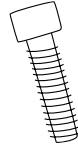

11 x8
Socket Cap Screw



12 x8
Blind Rivet

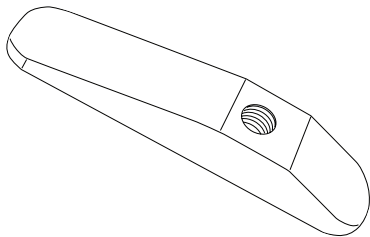

13 x4
Mounting Insert

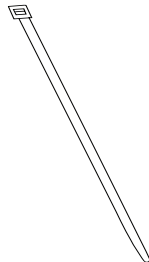

14 x20
Cable tie (7")

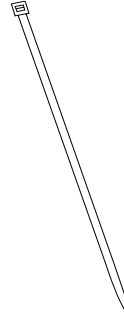

15 x2
Cable tie (11")

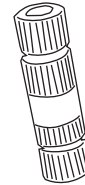

16 x4
Posi-Taps™ (Red/Grey)

17
Damper Bracket Kit
(Only needed for 1500 Quad Cab)

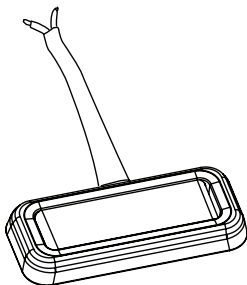

18 x4
LED Lamp

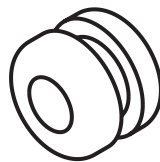

19 x4
Grommet

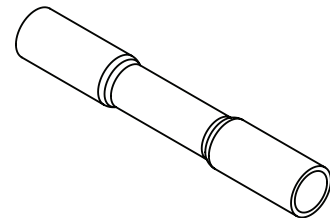

20 x8
Butt Connector

Note: Steps 1-8 shown on driver side.
Repeat these steps on passenger side.

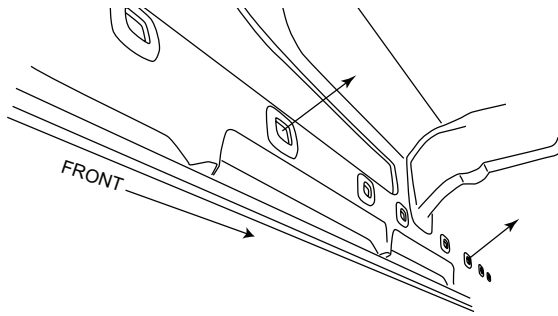

Counting large oval sill holes from the front, remove covering (plug or tape) from the below indicated mounting points.

1 QUAD CAB: 3rd and 7th from the front.
MEGA CAB: 3rd and 8th from the front.

Prepare brackets for install

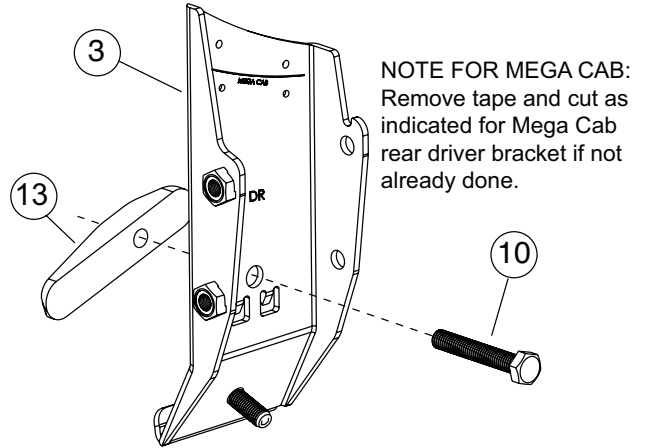

NOTE FOR MEGA CAB:
Remove tape and cut as indicated for Mega Cab rear driver bracket if not already done.

2 DRIVER REAR BRACKET SHOWN

Install rear mounting bracket

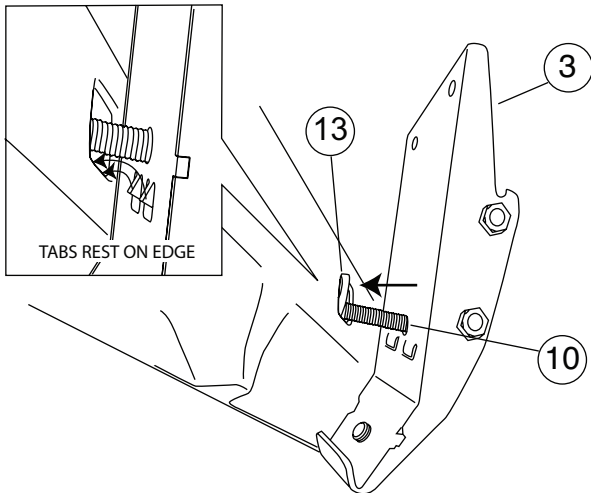

3

Fasten down rear mounting bracket

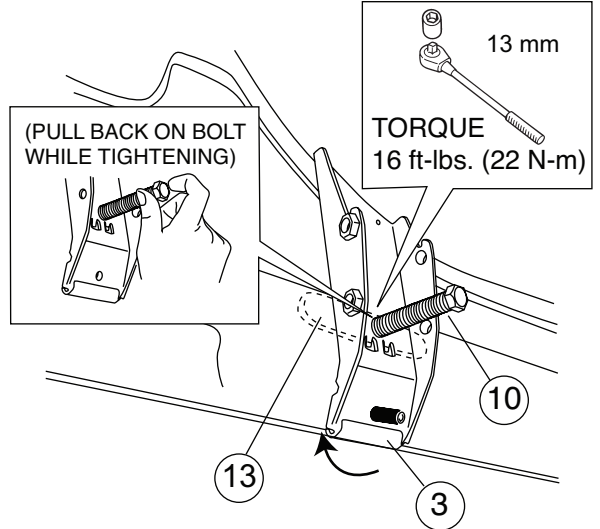

4

After drilling apply
paint to prevent
rusting.

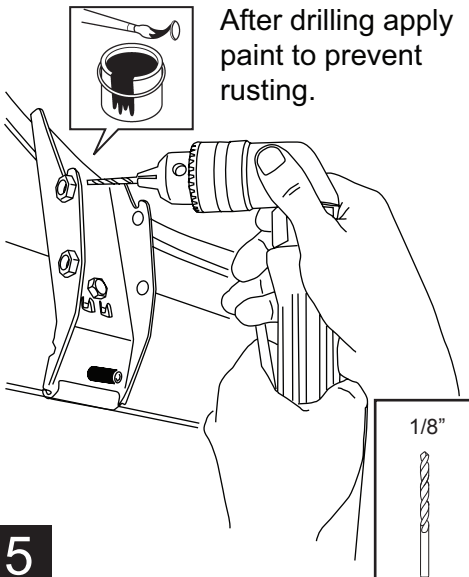

5

Bracket must be flush with the
sidewall before riveting.

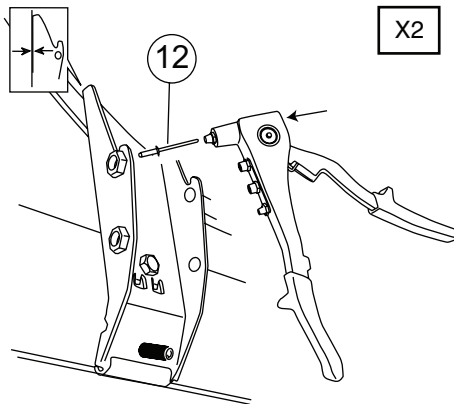

6

TORQUE
1.5 ft-lbs. (2 N-m)

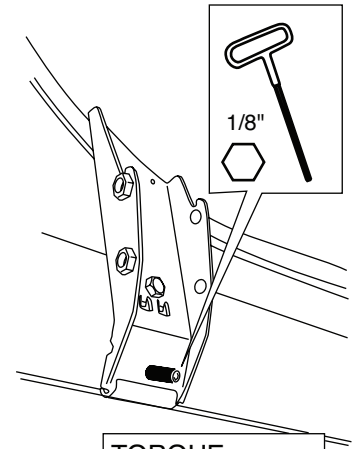

7

Repeat steps 2 thru 6 for front mounting bracket.

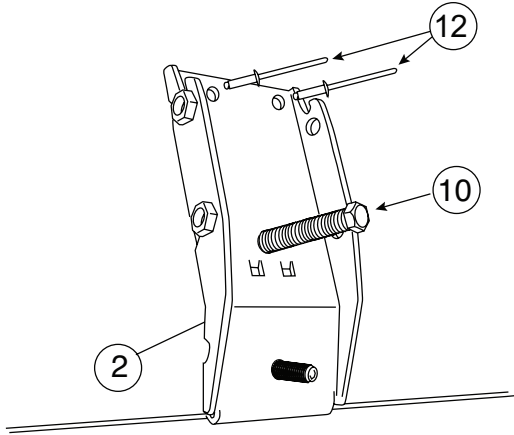

8

DRIVER SIDE

TORQUE
16 ft-lbs. (22 N-m)

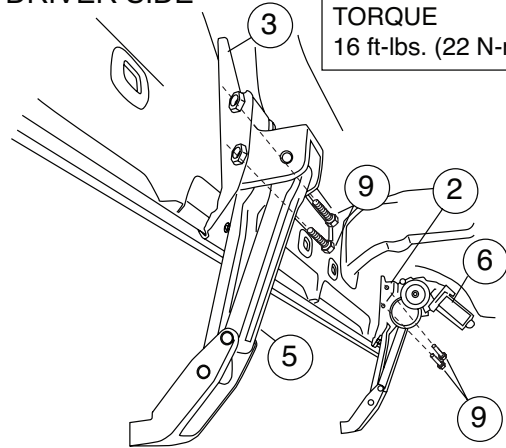

CAUTION: Swing in idler arm can cause pinch point.

9

PASSENGER SIDE

Install rear mounting bracket

TORQUE
16 ft-lbs. (22 N-m)

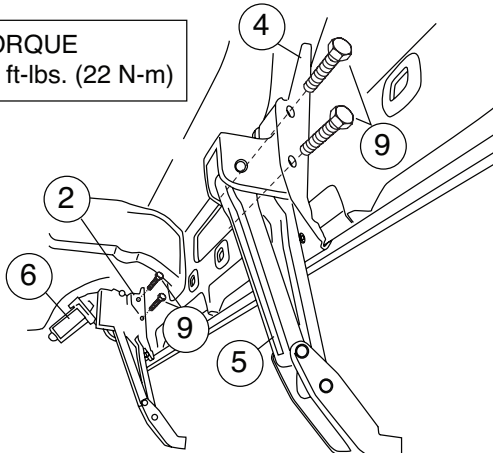

CAUTION: SWING IN IDLER ARM CAN CAUSE PINCH POINT

Mount step extrusion to linkage assemblies. Fasten loosely to allow for adjustments.

10

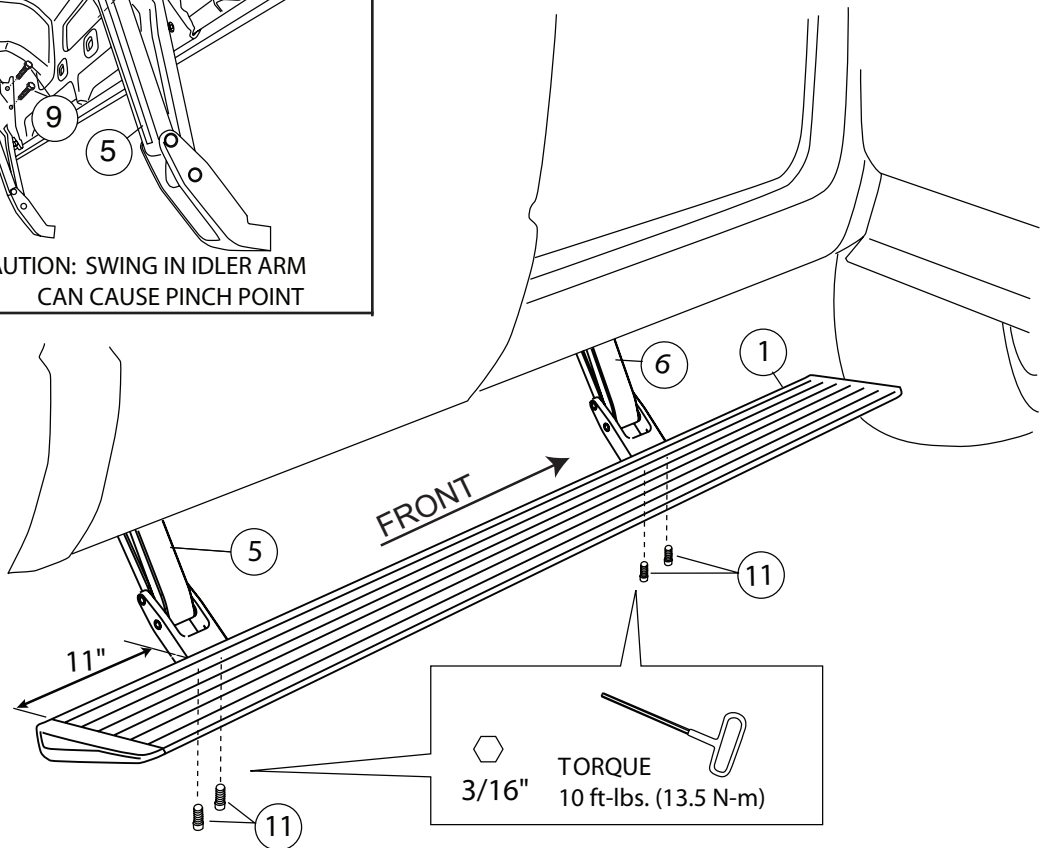

TORQUE
3/16" 10 ft-lbs. (13.5 N-m)

11

Attach 11" cable ties loosely around harness.

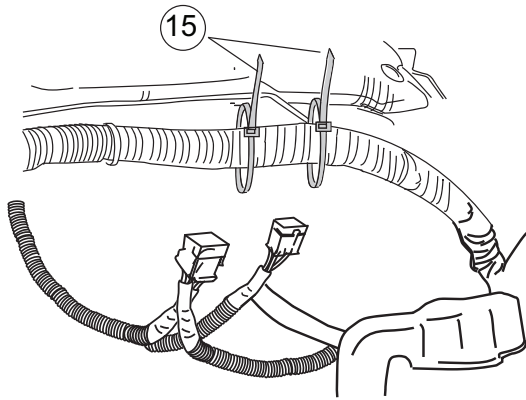

Attach wire harness to the control box. Slide controller through cable ties. Line up cable ties with grooves in controller and tighten.

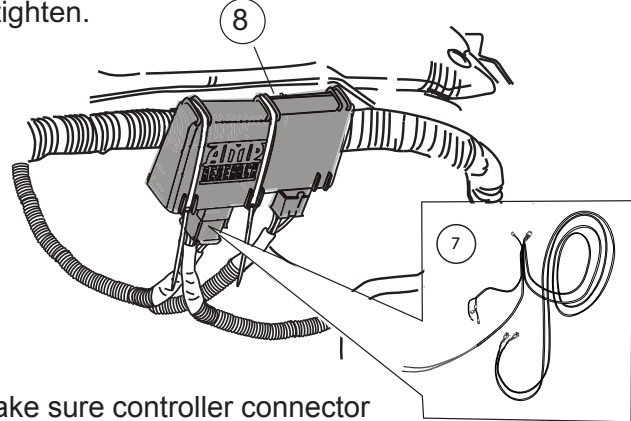

Note: Make sure controller connector locking tabs fully engage.

12

Remove fuse from Power Step wire harness.

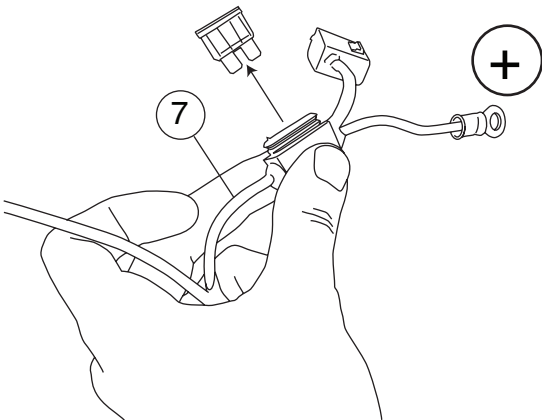

Attach power leads, red lead to positive battery terminal and the black lead to body ground as shown.

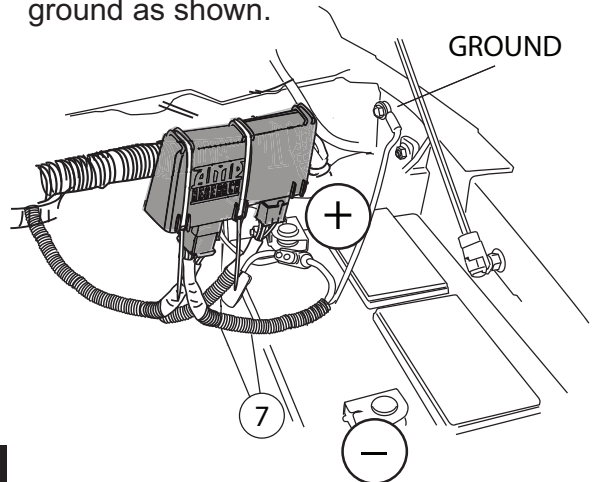

13

14

Route long leg of wire harness to passenger side across fire wall. Secure with tie wraps.

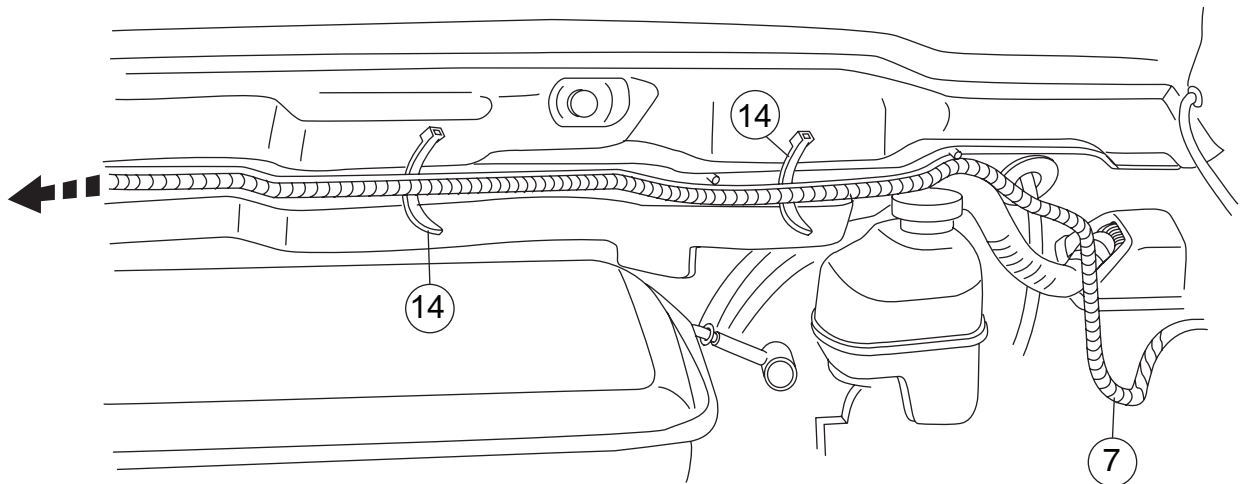

15

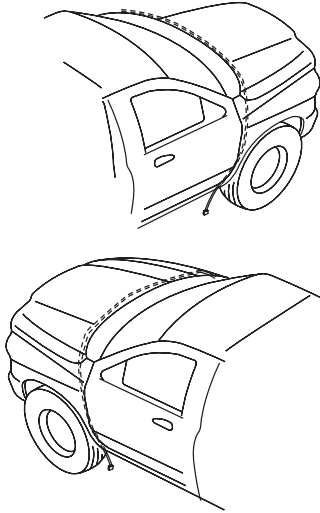

16

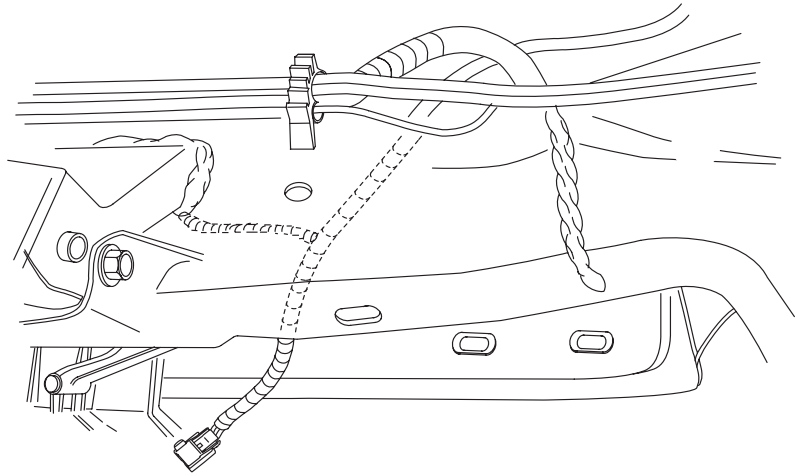

17

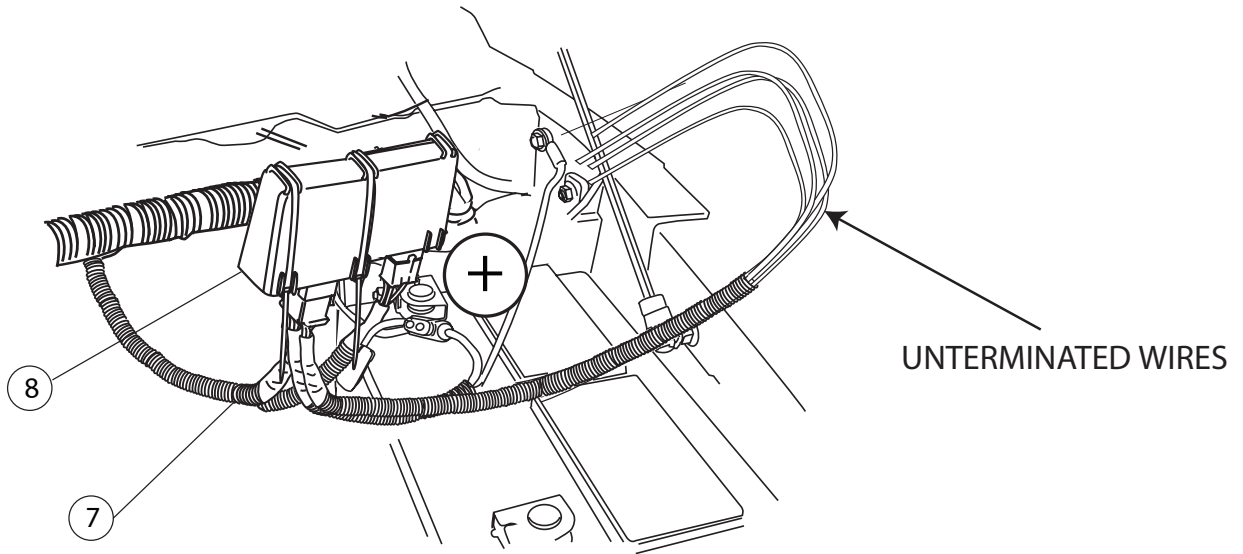

18

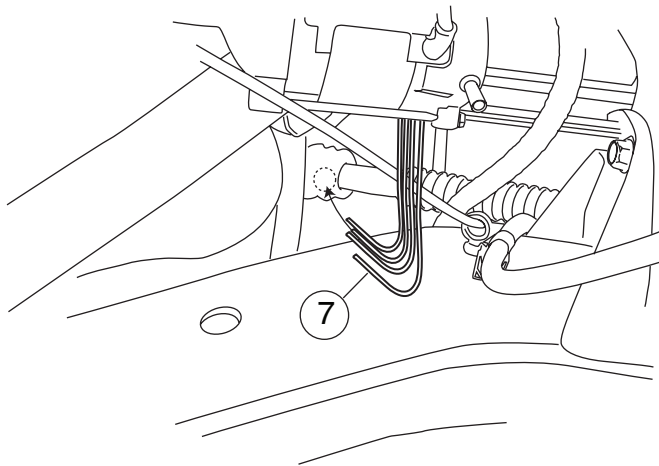

UNDER SIDE OF VEHICLE

19

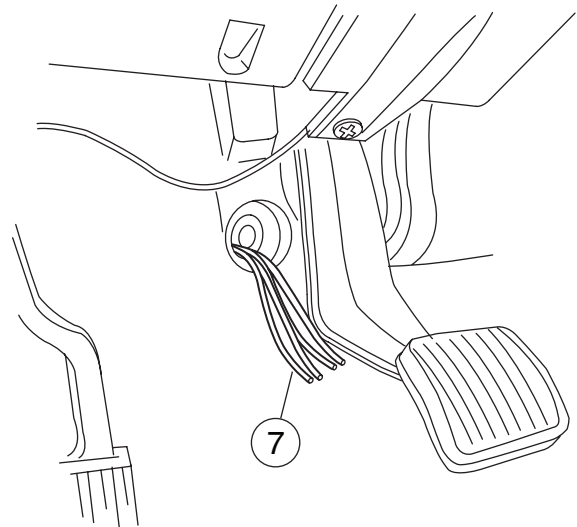

20

Remove plastic panel beneath steering column.

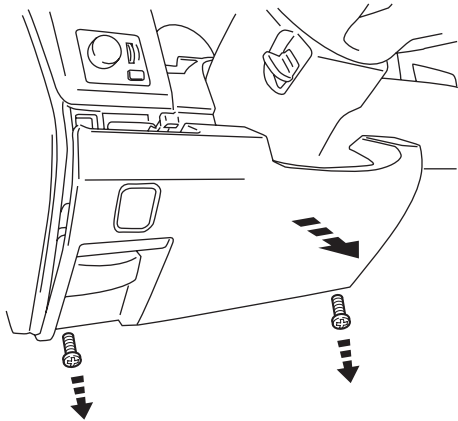

21

Remove metal panel revealed by step 21. Model years 2002-2005 will not have this panel to remove.

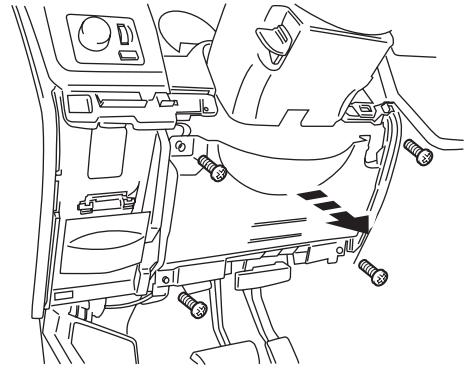

22

For 2006-2009 Models:

Locate bundle of wires high and to the left of diecast steering column mount.

Note: Bundle of wires leads toward back of fuel gauge and is located directly above bundle of wires grounded to left panel.

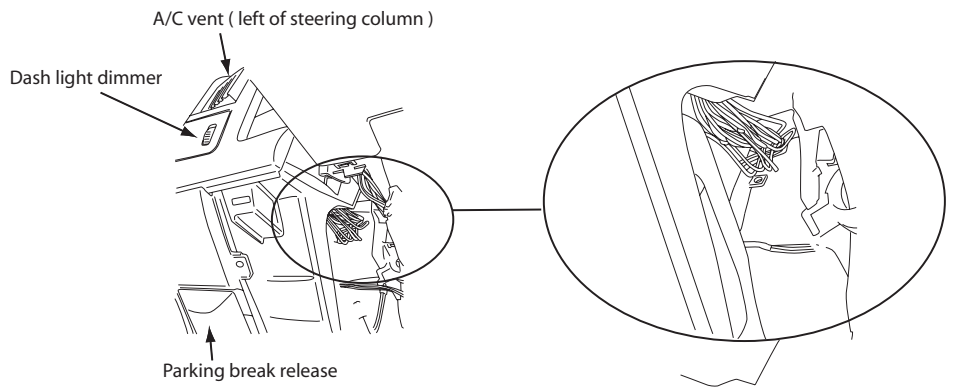

23

Pull wires through and run them up to the wires found in the previous step.

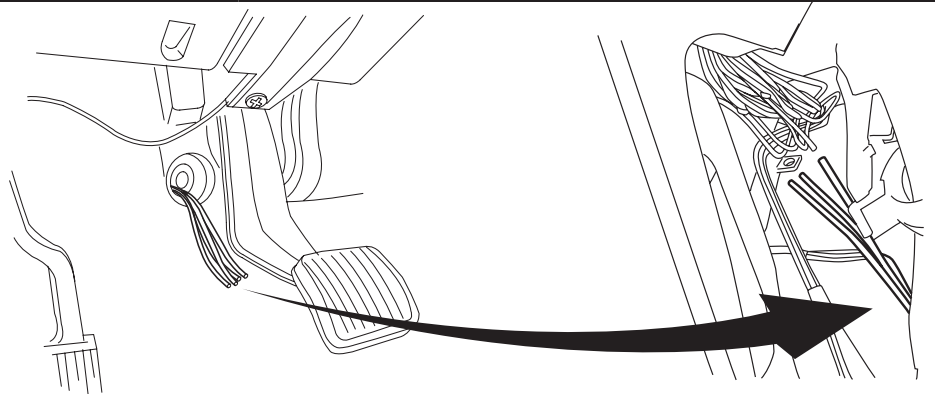

24

For 2002-2005 Models: Remove the cluster and instrument panel to access the grey plug.

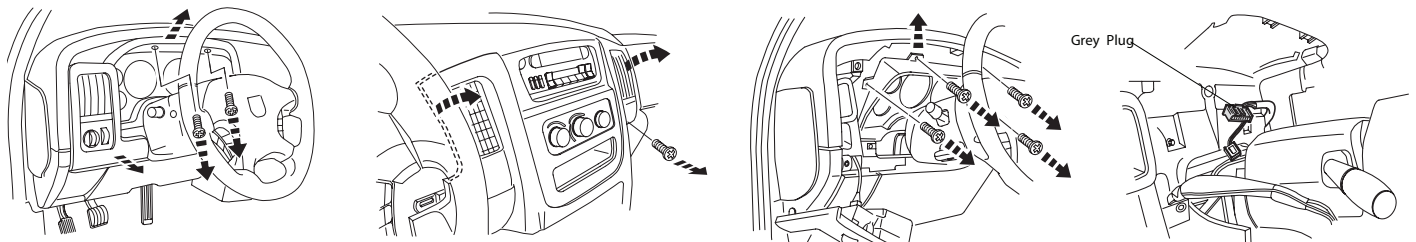

25

Model Years 2004-2009 Note: You may find two VL/YL wires in bundle. Only one works correctly.

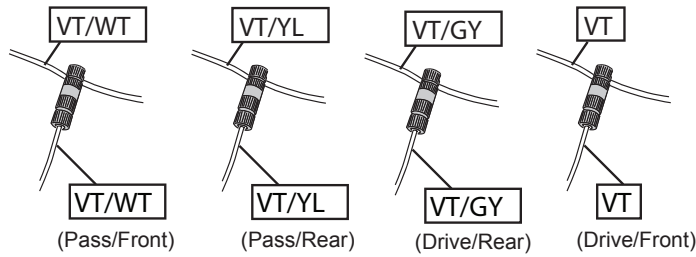

Using supplied Posi-Taps™ splice the Power Step trigger wires into their corresponding door ajar wire. See steps 26 and 27 for wire colors.

26

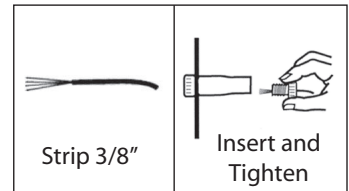

Model Years 2002-2003

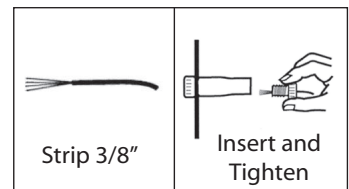
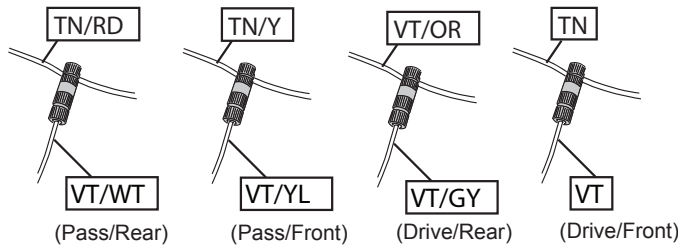

27

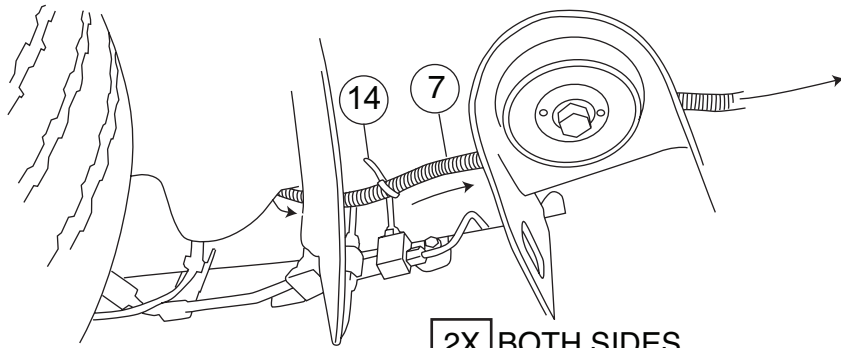

REINSTALL FUSE

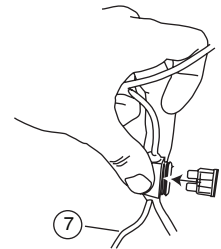

28

29

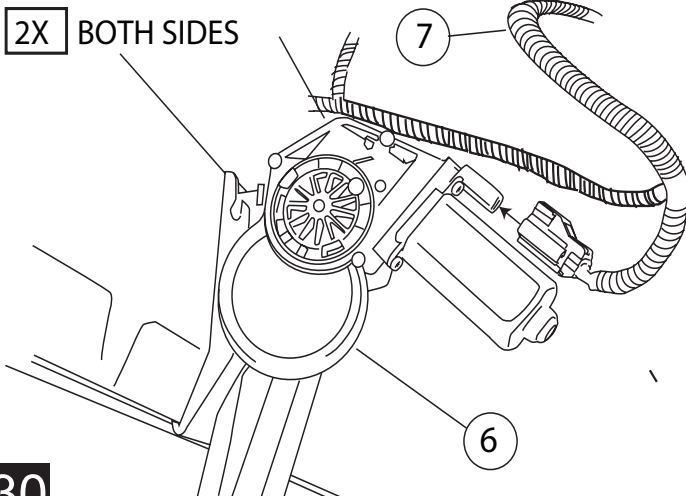

On each side of the vehicle measure from the front edge of door line on the pinch weld to the specified lengths below. Measure at 26" for the front LED Light and 58" for the rear LED Light.

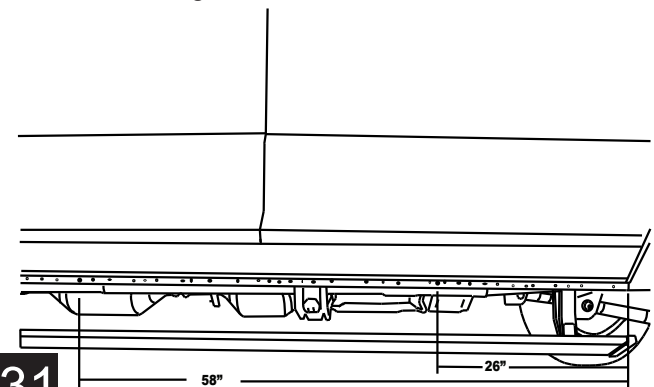

30

31

Drill a 9/32" hole through the pinch weld at marked locations. Deburr all holes.

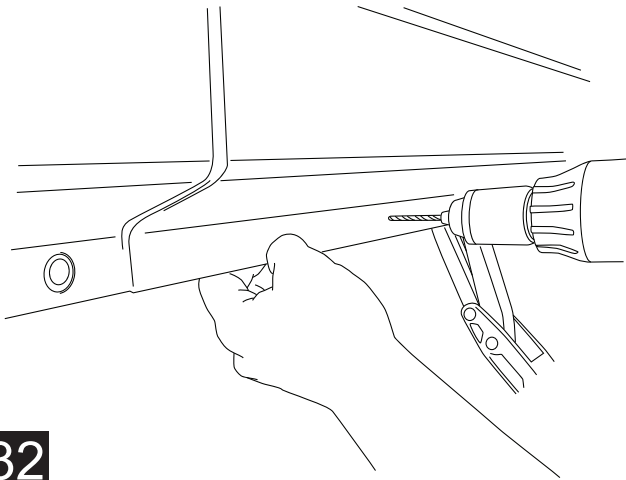

32

Insert grommet into drilled holes. Insert lamp wires through the grommets.

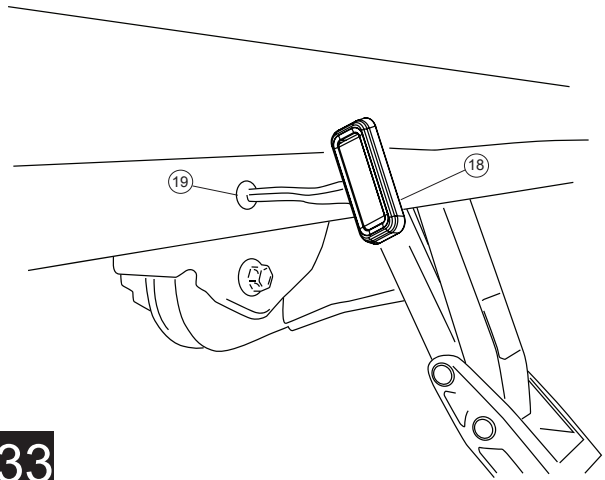

33

Affix lamp to rocker panel surface. Make sure lamp is affixed to a flat, clean surface.

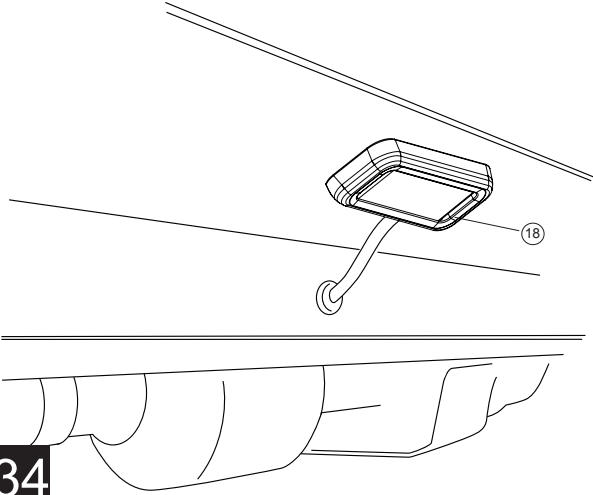

34

Using supplied butt connectors, connect the lamp wires. Red to Red, Black to Black. Once Crimped use heat gun to shrink tube.

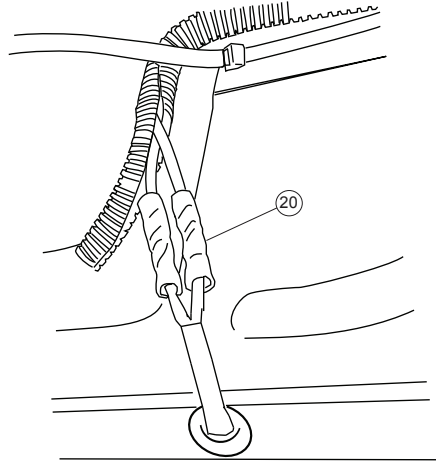

35

Close and wrap with conduit and electrical tape. Secure all loose wires with cable ties, with lamp wires pulled upward to avoid any wire snagging.

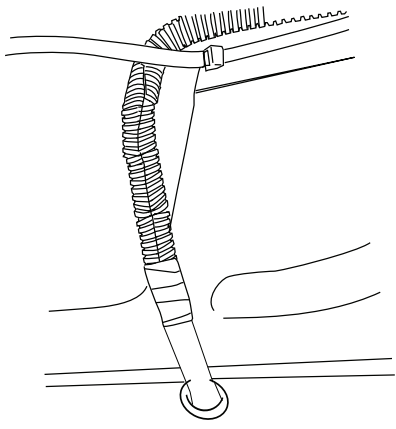

36

Reinstall fuse.

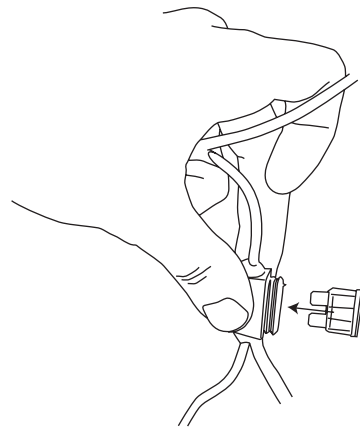

37

Check that all doors activate the Power Step and the LED Lights work when doors open and close. Reinstall any remaining trim panels.

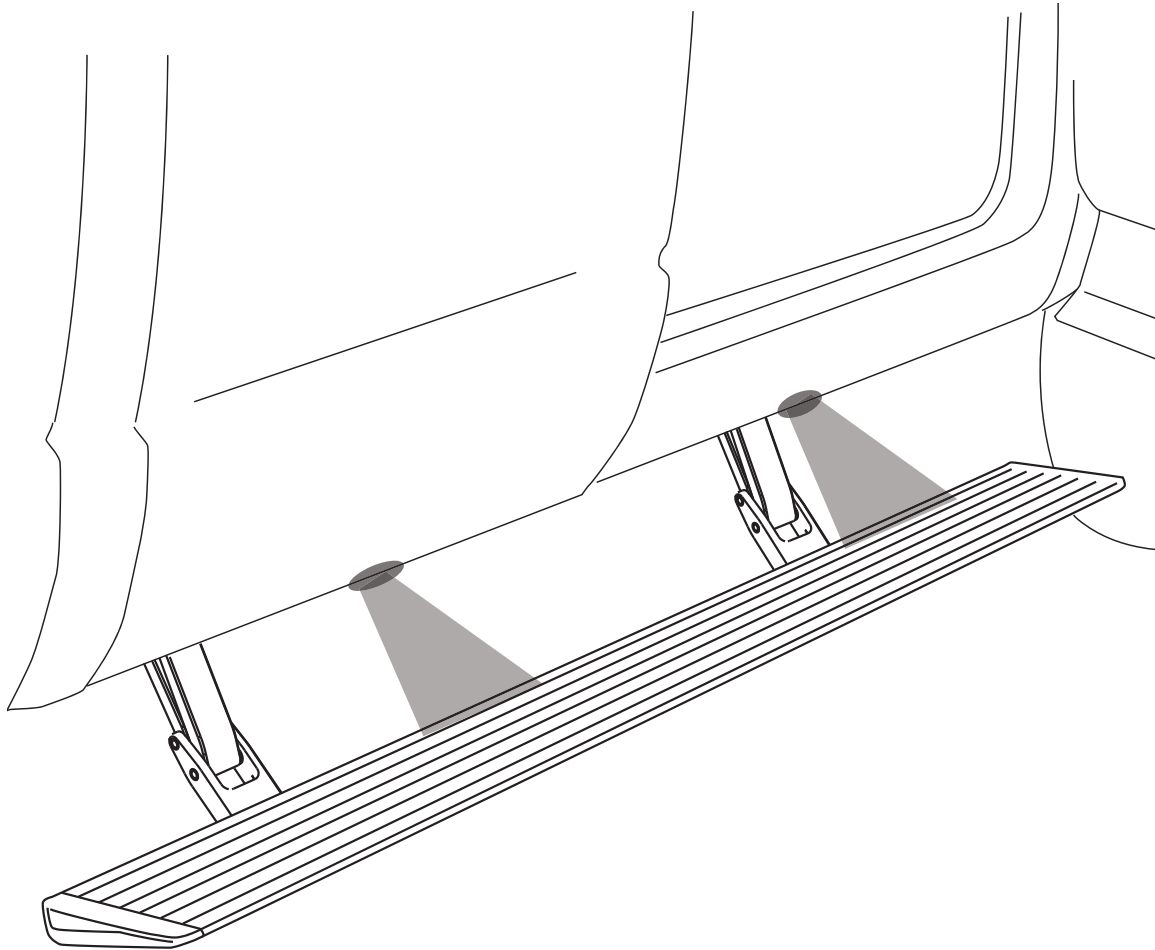

FINAL SYSTEM CHECK

Check that all doors activate the PowerStep and the LED lights work when doors open and close.

NORMAL OPERATION: When the doors open, PowerStep automatically deploys from under the vehicle. When the doors are closed, PowerStep will automatically return to the stowed/retracted position. **Note that there is a 2-second delay before the PowerStep returns to the stowed/retracted position.**

CORRECT OPERATION OF LIGHTS: All four lamps will illuminate upon opening any door of vehicle. Lamps will stay on until restowing of both Power Steps or until 5 minutes has expired with the doors open. When the lights timeout after 5 minutes, they can be reilluminated by closing and opening any door of vehicle.

Congratulations on the purchase of your AMP Research Power Step



Here's what you should know...

OPERATION

The AMP Research Power Step automatically deploys when at least one door opens and automatically retracts under your vehicle when both front and rear doors close. If resistance or blockage is encountered while the Power Step is in motion, the drive system is designed to automatically stop. To reset, simply open or close the vehicle door and the Power Step will resume normal operation.

MAINTENANCE TIPS

The stepping surface and drive mechanism can be washed with mild soap and water using a soft brush or sponge to dislodge any mud, dirt or accumulated road grime. Rinse with fresh water.

To prevent slipping, avoid applying waxes, lubricants or protectants like Armor All® to the step surface.

When washing your vehicle, the Power Steps can be set to remain deployed with the doors closed for easy cleaning. Do this...

- 1** With the Power Step deployed, press and hold the board down with your foot.
- 2** Close the door while continuing to press down the board. (This will not harm motor.)
- 3** To reset the Power Step, simply open and close the door. (Repeat for both sides of vehicle.)

CAUTION! BE SURE TO KEEP HANDS AWAY WHEN THE POWER STEP IS IN MOTION.

amp-research.com

LIMITED WARRANTY

AMP RESEARCH warrants product to be free from defects in material and workmanship, for terms specified below, provided there has been normal use and proper maintenance. This warranty applies to the original purchaser only. All remedies under this warranty are limited to the repair or replacement of any item found by the factory to be defective within the time period specified.

If you have a warranty claim, first you must call our factory at the number below for instructions. You must retain proof of purchase and submit a copy with any items returned for warranty work. Upon completion of warranty work, if any, we will return the repaired or replaced item or items to you freight prepaid. Damage to our products caused by accidents, fire, vandalism, negligence, misinstallation, misuse, Acts of God, or by defective parts not manufactured by us, is not covered under this warranty.

THE WARRANTY TIME PERIOD IS AS FOLLOWS: THREE YEARS FROM DATE OF PURCHASE.

ANY IMPLIED WARRANTIES OF MERCHANTABILITY AND/OR FITNESS FOR A PARTICULAR PURPOSE CREATED HEREBY ARE LIMITED IN DURATION TO THE SAME DURATION AND SCOPE AS THE EXPRESS WRITTEN WARRANTY. OUR COMPANY SHALL NOT BE LIABLE FOR ANY INCIDENTAL OR CONSEQUENTIAL DAMAGE.

Some states do not allow limitations on how long an implied warranty lasts, or the exclusion or limitation of incidental or consequential damages, so the above limitations or exclusions may not apply to you. This warranty gives you specific legal rights, and you may also have other rights that vary from state to state.

FOR WARRANTY ISSUES WITH THIS PRODUCT PLEASE CALL AMP RESEARCH CUSTOMER SERVICE 1-888-983-2204

WARNING

Be sure to read and precisely follow the provided instructions when installing this product. Failure to do so could place the vehicle occupants in a potentially dangerous situation. After installing or reinstalling, re-check to insure that the product is properly installed.