

# AMP RESEARCH BedStep2™

## APPLICATION

Dodge Ram DS

3500

2019 - 2020

Dually 8' Bed only!

AMP PART # 75419-01A

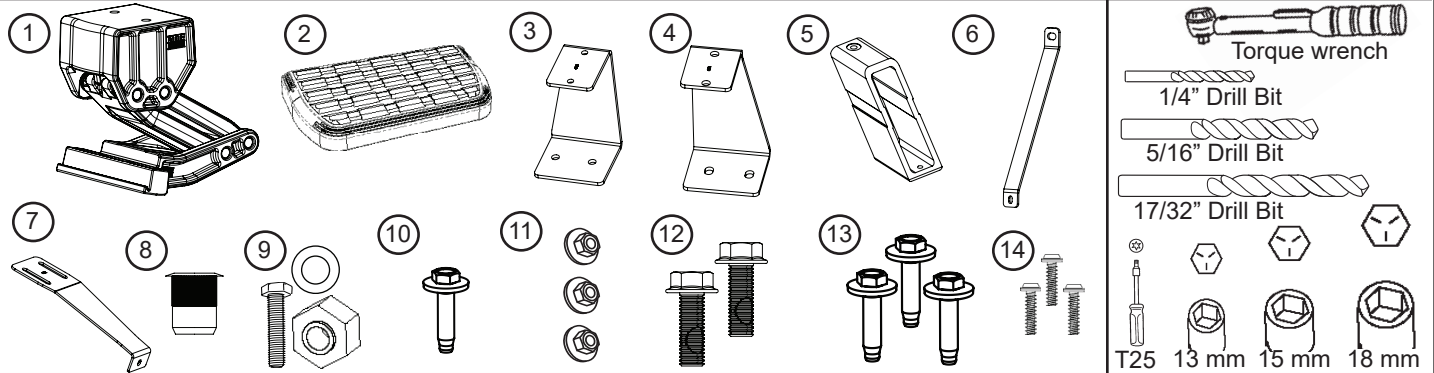

Components must be configured for Passenger or Drivers-Side as shown.

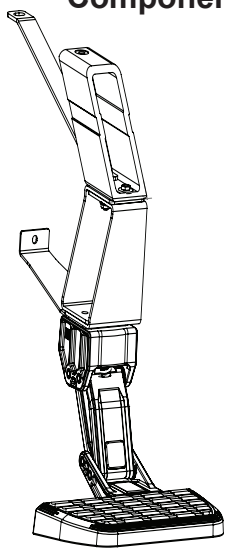

**Driver-Side Orientation**

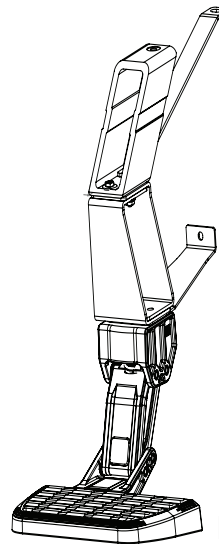

**Passenger-Side Orientation**

Assemble Frame mount(5) to Lateral mount(3,4) with Bracket(6) using supplied M8 Conical bolts(13) and Conical Nuts (11). Do not tighten.

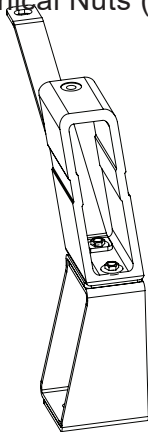

**1**



13mm

**2**

Assemble Linkage Assembly(1) to Lateral mount assembly with Bracket(7) between using M10 Flange bolts(12). Do not tighten.

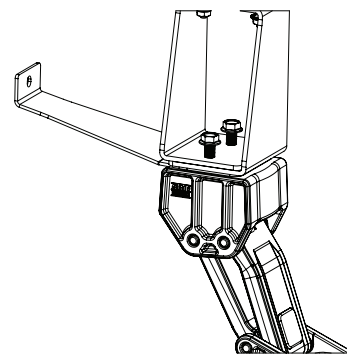

15mm

AMP RESEARCH TECH SUPPORT 1-888-983-2204 (Press 2) Monday - Friday, 6:00 AM - 5:00 PM PST

BedStep2™ is invented, designed, engineered and manufactured exclusively by AMP Research and may be covered by one of the following patents: 6,641,158; 6,830,257; 6,938,909; 7,055,839; 7,380,807; 7,398,985; 7,584,975. Made in USA © 2011 AMP Research

Three-year limited warranty. Professional installation is recommended.

Locate Bed bolt in second bed channel back from the front. Remove bolt.

**NOTE: DRIVER SIDE SHOWN**

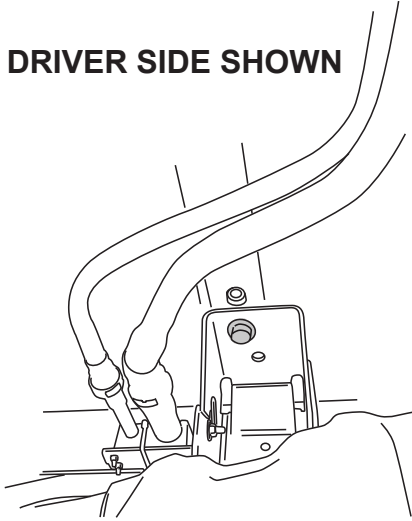

**3**

Set assembly into place as shown and mark hole in bed channel for rivet nut placement.

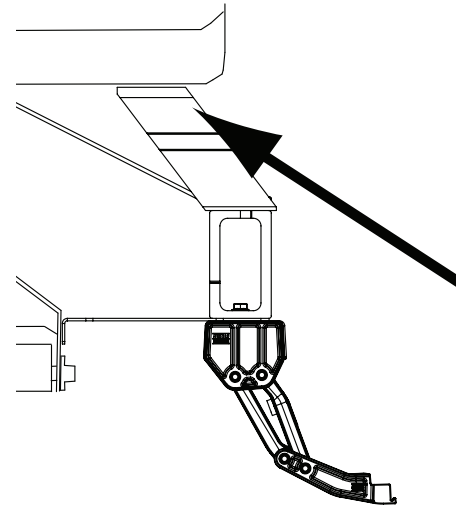

**4**

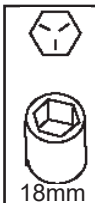

Once hole is marked remove Bedstep Assembly and pre drill using an 1/8" drill bit. Drill to 17/32". With Rivet Nut Tool held in place with 9/16" wrench, tighten Hex Bolt until Rivet Nut deforms and secures itself to the sheet metal (20 ft-Lbs. or 4 turns). Remove Hex Bolt and Rivet Nut Tool.

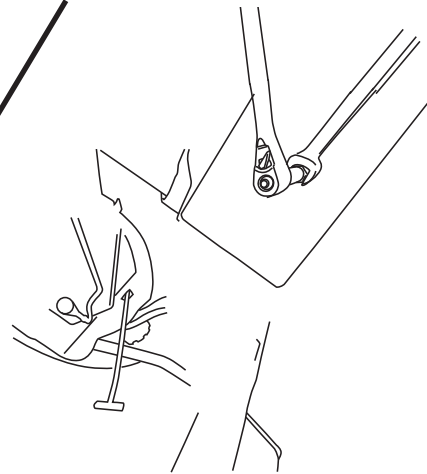
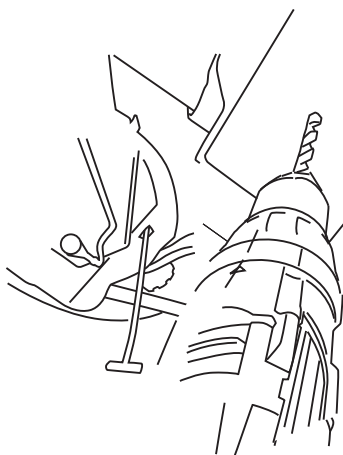

**5**

Reassemble Bedstep Assembly under truck and snug the three locations up.

A. Torque bed bolt to 35 ft-lbs. B. Torque frame mount bolt to 20 ft-lbs. C. Use provided bolt(10), Nut(11) to secure bracket to leafspring hanger. Torque to 20 ft-lbs.

**Note if vehicle does not have hole mark and drill hole to 5/16".**

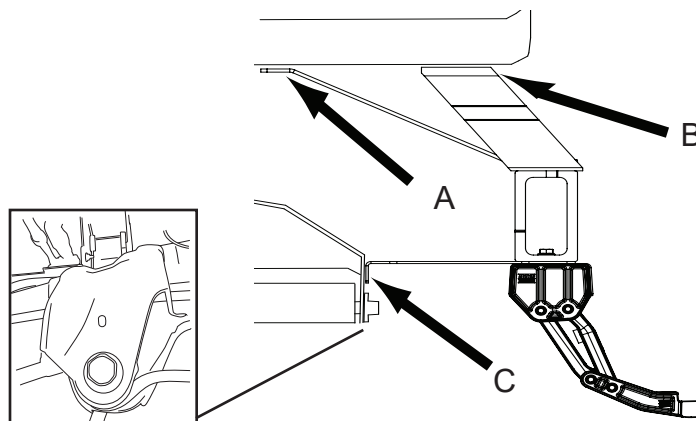

**6**

Locate the step pad in the following position. Step pad to be offset forward. Torque to 5 Ft-Lbs.

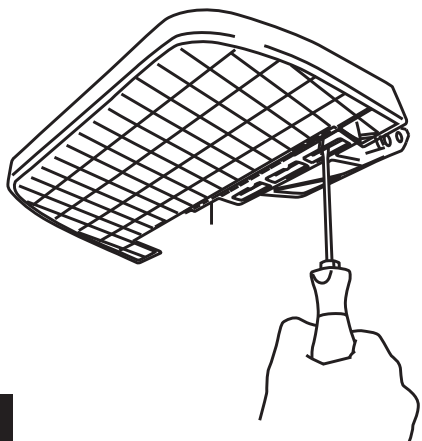

7

T25

Verify step pad alignment to body line of vehicle.

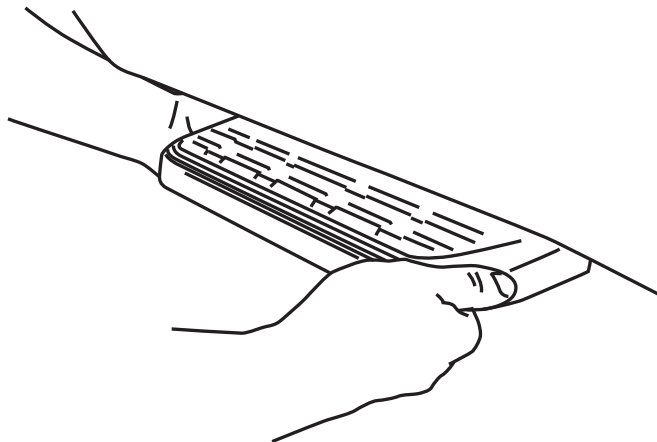

8

Torque bolts from step 1 & 2. A. Torque bolts to 20ft-lbs. B. Torque bolts to 20 ft-lbs.

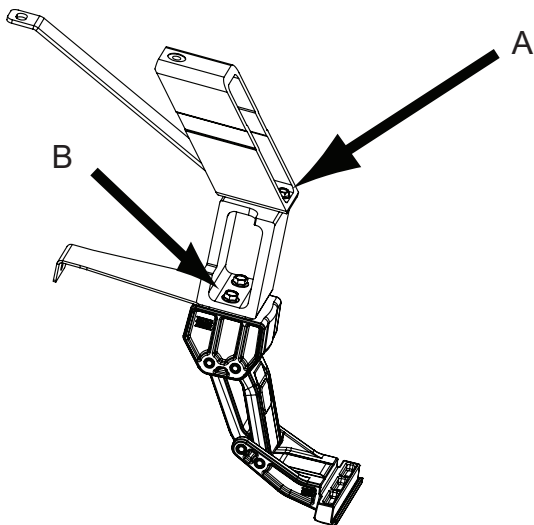

9

13mm

To deploy step pad press down using your foot on the outer edge of the step pad. To retract, gently kick up on the underside of the step pad.

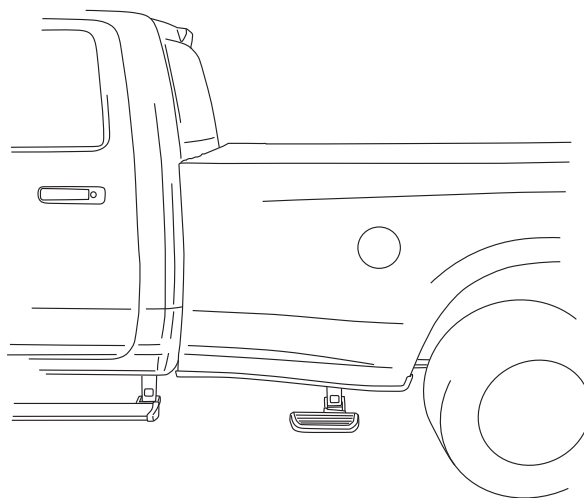
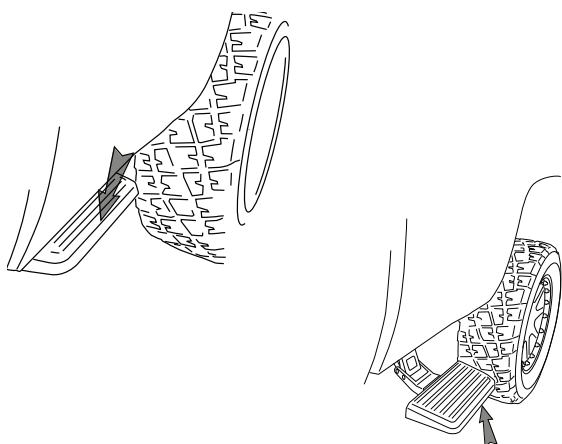

10



Congratulations on your purchase of the genuine AMP Research BedStep2™. Here's what you should know...



### BEDSTEP2™ OPERATION

The AMP Research BedStep2™ is foot operated and deploys and retracts with a nudge of your foot. To deploy, press down using your foot, on the outside edge of the step pad. Maximum load capacity of the deployed step pad is 300 lbs. Always use appropriate hand holds when stepping up to or down from your truck's cargo bed.



To retract, gently kick up on the underside of the step pad.

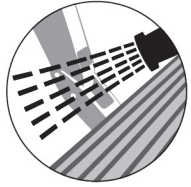

**MAINTENANCE TIPS** - The stepping surface and linkage should be periodically washed with mild soap and water using a soft brush or sponge to dislodge any mud, dirt or accumulated road grime. **In severe driving conditions, pressure washing the linkage is strongly recommended.** Do not apply silicone spray, waxes or protectants like Armor All® to the stepping surfaces.

**CAUTION! BEDSTEP2™ SHOULD ALWAYS BE STOWED IN THE RETRACTED POSITION WHEN DRIVING.**

### AMP RESEARCH LIMITED WARRANTY

AMP RESEARCH warrants this product to be free from defects in material and workmanship for THREE (3) YEARS FROM DATE OF PURCHASE, provided there has been normal use and proper maintenance. This warranty applies to the original purchaser only. All remedies under this warranty are limited to the repair replacement of the product itself, or the repair or replacement of any component part thereof, found by the factory to be defective within the time period specified. The decision to repair or replace is wholly within the discretion of the manufacturer.

This warranty specifically excludes labor. If you have a warranty claim, first you must call our factory at the number below for instructions. You must retain proof of purchase and submit a copy with any items returned for warranty work. Upon completion of warranty work, if any, we will return the repaired or replaced item or items to you freight prepaid. Damage to our products caused by accidents, fire, vandalism, negligence, misinstallation, misuse, Acts of God, or by defective parts not manufactured by us, is not covered under this warranty.

ANY IMPLIED WARRANTIES OF MERCHANTABILITY AND/OR FITNESS FOR A PARTICULAR PURPOSE CREATED HEREBY ARE LIMITED IN DURATION TO THE SAME DURATION AND SCOPE AS THE EXPRESS WRITTEN WARRANTY. OUR COMPANY SHALL NOT BE LIABLE FOR ANY INCIDENTAL OR CONSEQUENTIAL DAMAGE.

Some states do not allow limitations on how long an implied warranty lasts, or the exclusion or limitation of incidental or consequential damages, so the above limitations or exclusions may not apply to you. This warranty gives you specific legal rights, and you may also have other rights that vary from state to state.

**FOR WARRANTY ISSUES WITH THIS PRODUCT PLEASE CALL AMP RESEARCH CUSTOMER SERVICE 1-888-983-2204**

### WARNING

Be sure to read and precisely follow the provided instructions when installing this product. Failure to do so could place the vehicle occupants in a potentially dangerous situation. After installing or reinstalling, re-check to insure that the product is properly installed.