



AUTOMOTIVE PRODUCTS,

INSTALLATION INSTRUCTIONS

ULTIMATE BULL BAR

APPLICATION:

2010-2017 Toyota 4Runner
(Excludes 2014-2017 "Limited" Model)

PART NUMBER:

32-3600, 32-3605, 32-3605L

ITEM	QUANTITY	DESCRIPTION	TOOLS NEEDED
1	1	ULTIMATE BULL BAR	5/8" SOCKET
2,3	2	MOUNTING BRACKET, DRIVER (2) AND PASSENGER (3)	5/8"WRENCH
4	4	7/16" HEX BOLT	13MM WRENCH
5	4	7/16" HEX NUT	RATCHET
6	8	7/16" FLAT WASHER	TORQUE WRENCH
7	4	7/16" LOCK WASHER	
8	1	LED WIRING HARNESS (09-12000-1)	

ANTI-SEIZE LUBRICANT MUST BE USED ON ALL STAINLESS STEEL FASTENERS TO PREVENT THREAD DAMAGE AND GALLING

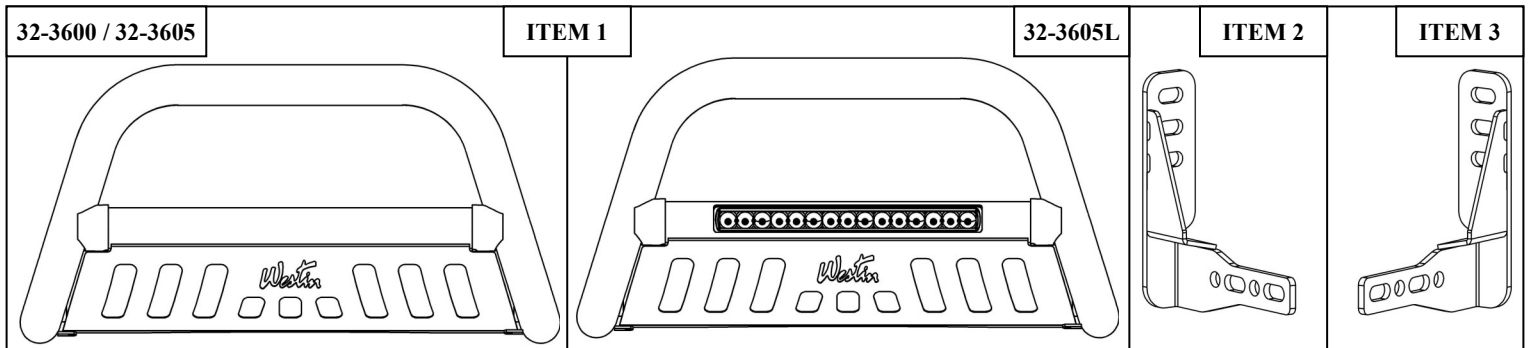

PROCEDURE

- Remove contents from box, verify if all parts listed are present and free from damage. Carefully read and understand all instructions before attempting installation.
Failure to identify damage before installation could lead to a rejection of any claim.
- For 2010-2013 vehicles only:** From underneath the front of the vehicle, remove the drivers side and passenger side plastic splash guards and set aside. See **Figure 1**.
- Starting on the driver's side, remove the three factory bumper mount nuts (located toward the outside of the bumper mount). Take the drivers side frame mounting bracket and insert it into the opening in the back of the bumper cover. **Note:** 2014+ vehicles do not have this opening. Line up the three slots in the mounting bracket with the factory stud locations, secure the mounting bracket to the frame using the factory nuts. Do not fully tighten hardware at this time. See **Figure 2**.
- Repeat **Step 3** for passenger side bracket installation.
- Take the Bull Bar and line up the mounting tabs with the two previously installed mounting brackets. Attach the bull bar to the brackets using (4) 7/16" hex head bolts, (8) 7/16" flat washers, (4) 7/16" lock washers, and (4) 7/16" hex nuts. Refer to **Figures 3 & 4**. **Note:** For 2010-2013 vehicles mount the Bull Bar to the slots in the brackets. For 2014+ vehicles mount the Bull Bar to the holes in the brackets.
- Align and adjust the Bull Bar as necessary then tighten all hardware at this time. Tighten and torque factory M10 hardware and supplied 7/16" hardware to 30-35 ft-lbs.



Westin Automotive Products, Inc.
320 W. Covina Blvd
San Dimas, Ca. 91773

Thank you for choosing Westin products
for additional installation assistance please call
Customer Service (800) 793-7846

7. **For 2010-13 vehicles only:** Take the driver's side splash guard and position it against the frame mounting bracket and mark the area that needs to be cut from the splash guard to clear the bracket. Cut only the minimum amount to clear; then re-install the splash guard. Repeat this step for the passenger side.
8. **For part number 32-3605L:** Refer to **Page 3** for wiring instructions. Loosen M8 hardware to adjust the LED light in bull bar or to remove it in order to replace it. See **Figure 5** for location of M8 hardware.

Remove the splash shields from both sides of the vehicle (2010 - 2013 only - Driver side shown).



Figure 1

Install the Mounting Brackets to the vehicle's bumper support plate using factory hardware. (Driver side shown)

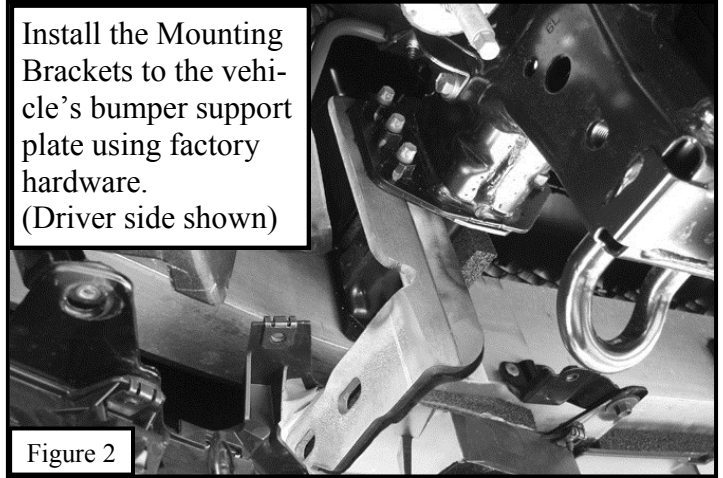

Figure 2

Install the Bull Bar to the Mounting Brackets using 7/16 hardware (Driver Side Shown).

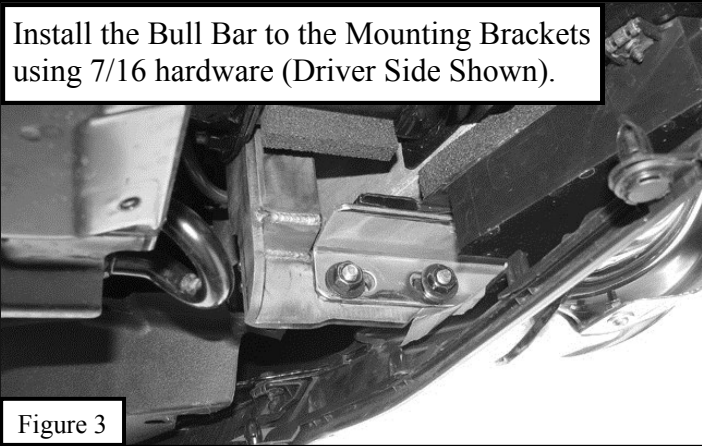

Figure 3



Figure 4

INSTALLATION COMPLETE



CARE INSTRUCTIONS

- REGULAR WAXING IS RECOMMENDED. DO NOT USE ANY TYPE OF POLISH OR WAX THAT MAY CONTAIN ABRASIVES.
- STAINLESS STEEL PRODUCTS CAN BE CLEANED WITH MILD SOAP AND WATER. STAINLESS STEEL POLISH SHOULD BE USED TO POLISH SMALL SCRATCHES.
- GLOSS BLACK FINISHES SHOULD BE CLEANED WITH MILD SOAP AND WATER.



Westin Automotive Products, Inc.
320 W. Covina Blvd
San Dimas, Ca. 91773

Thank you for choosing Westin products
for additional installation assistance please call
Customer Service (800) 793-7846

www.westinautomotive.com

DATE: 2/8/17

WIRING INSTRUCTIONS:

WESTIN recommends using a professional for this installation.

CAUTION:

1. Disconnect ground connection from battery (-) to avoid accidental short circuits before attempting to connect electrical wires.
2. When running wires, avoid areas of excessive heat, vibration, pinch or rotation when securing harness to vehicle.
3. Always use a fused (+) positive supply source.
4. This light becomes hot under continuous use. Do not remove or touch the casting for at least 30 minutes after the lamp has been turned off.

Refer to Figure 6.

1. Locate wiring harness and mount the switch in a convenient location where it is easily accessible from the drivers seat.
Note: *The switch will need to be removed from the wiring harness so that the rest of the harness can be routed from the engine bay to the cabin.*
2. Route the wiring harness wire, specifically the fuse and relay, from the positive battery terminal along the firewalls existing wire routes. **Note:** *Tape as necessary to correct slack.*
3. Secure the relay by either drilling or using a pre-existing bolt along the chassis that is not connected to any other wire.
4. Run the switch harness through the firewall preferably through the pre-existing rubber plug that is used to run the OEM wiring harness from the engine bay to fuse box. **Note:** *Reconnect the switch to the wiring harness.*
5. Place the LED plug wire along the fender chassis where it will not get pinched and away from any moving parts (fan, pulleys etc.).
6. Run the attached wire from the LED Light Bar as previously mentioned away from any moving parts.
7. Connect both ends of wiring connectors from LED light bar and wiring harness.
8. Re-connect battery terminals, attach the Red (+) wire to battery positive, and the black (-) wire to ground. **Note:** *Add dielectric grease (not supplied).*
9. Turn on the switch to make sure if the lamp works. If not, please check carefully if the wiring installation is correct.

M8 hardware attaches LED light onto bull bar.

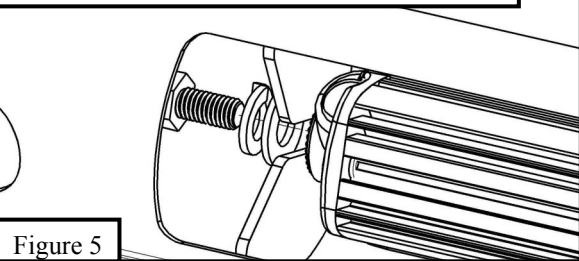

Figure 5

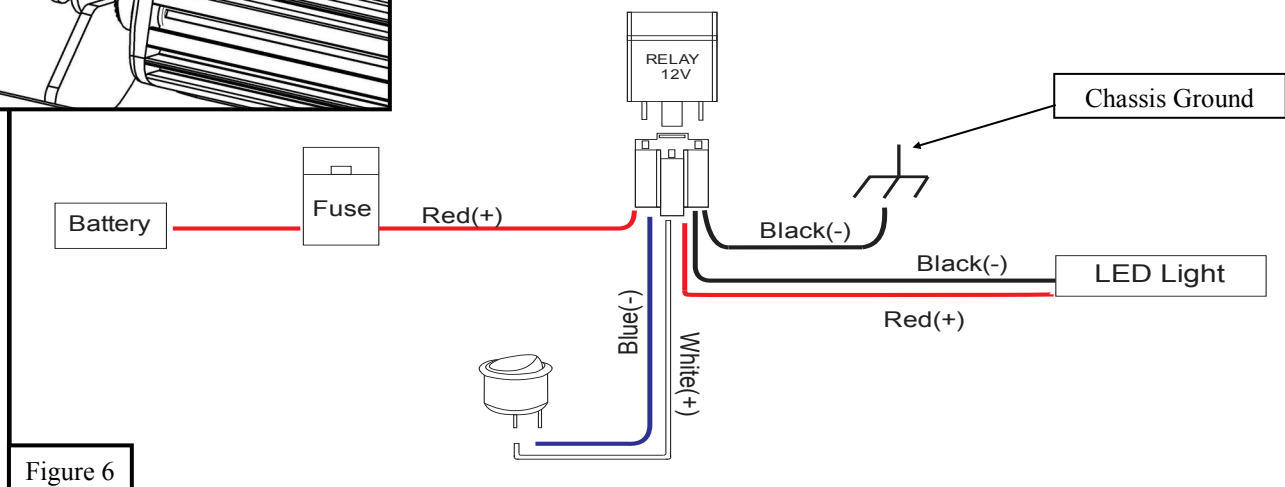

Figure 6



Westin Automotive Products, Inc.
320 W. Covina Blvd
San Dimas, Ca. 91773

Westin

SIGNATURE OF QUALITY

AUTOMOTIVE PRODUCTS, INC.



WARNING



Failure to follow these instructions could lead to death, personal injury, and / or property damage.

FASTENERS:

All Westin supplied fasteners must be utilized and installed in accordance with the installation instructions and apply torque to the specifications as defined. **DOUBLE CHECK ALL FASTENERS BEFORE INITIAL USE, AND PERIODICALLY IN THE FUTURE TO ENSURE PROPER FUNCTION AND SAFETY.**

DRILLING:

Most Westin products do not require drilling for installation. If drilling is defined as required, use caution when drilling a vehicle. **FAILURE TO REVIEW AN AREA TO BE DRILLED MAY RESULT IN PERSONAL INJURY AND/OR INJURY TO OTHERS AS WELL AS VEHICLE DAMAGE.**

EYE PROTECTION:

ALWAYS WEAR SAFETY GLASSES OR GOGGLES DURING THE INSTALLATION PROCESS TO AVOID PERSONAL INJURY.

MAXIMUM TOWING/CARRYING CAPACITY:

The Westin Receiver Hitches will have a visible tow rating label affixed directly on the product. User should never exceed the vehicle manufacturers maximum tow and weight rating regardless of the capacity of the hitch. **FAILURE TO FOLLOW THESE GUIDELINES WILL VOID THE WESTIN WARRANTY AND MAY RESULT IN PERSONAL INJURY AND/OR INJURY TO OTHERS AS WELL AS VEHICLE DAMAGE.**

Westin
SIGNATURE OF QUALITY

Westin Automotive Products, Inc.
320 W. Covina Blvd
San Dimas, Ca. 91773