



AUTOMOTIVE PRODUCTS,

# INSTALLATION INSTRUCTIONS

**ULTIMATE BULL BAR**  
**APPLICATION:**  
**2016 Toyota Tacoma**  
**PART NUMBER:**  
**32-3880, 32-3885**

ITEM	QUANTITY	DESCRIPTION	TOOLS NEEDED
1	1	ULTIMATE BULL BAR	3/16 ALLEN KEY
2,3	2	MOUNT BRACKET, DRIVER(2) AND PASSENGER(3)	17MM WRENCH
4,5	2	STRAP, DRIVER(4) AND PASSENGER(5)	19MM WRENCH
6	2	M12 HEX HEAD CAP SCREW (YELLOW ZINC)	7/16 WRENCH
7	2	M12 FLAT WASHER (YELLOW ZINC)	17MM SOCKET
8	2	M12 SPLIT LOCK WASHER (YELLOW ZINC)	19MM SOCKET
9	2	1/4-20" BUTTON HEAD BOLT (YELLOW ZINC)	7/16 SOCKET
10	4	1/4" FLAT WASHER (YELLOW ZINC)	RATCHET
11	2	1/4-20" HEX LOCK NUT (YELLOW ZINC)	TORQUE WRENCH
12	2	M10 BOLT PLATE (YELLOW ZINC)	
13	2	M10 HEX NUT (YELLOW ZINC)	
14	2	M10 FLAT WASHER (YELLOW ZINC)	
15	2	M10 LOCK WASHER (YELLOW ZINC)	
16	2	3/8-16" HEX SOCKET BUTTON HEAD SCREW (BLACK ZINC)	
17	2	3/8 FLAT WASHER (BLACK ZINC)	
18	2	3/8 SPLIT LOCK WASHER (BLACK ZINC)	

**ANTI-SEIZE LUBRICANT MUST BE USED ON ALL STAINLESS STEEL FASTENERS TO PREVENT THREAD DAMAGE AND GALLING**

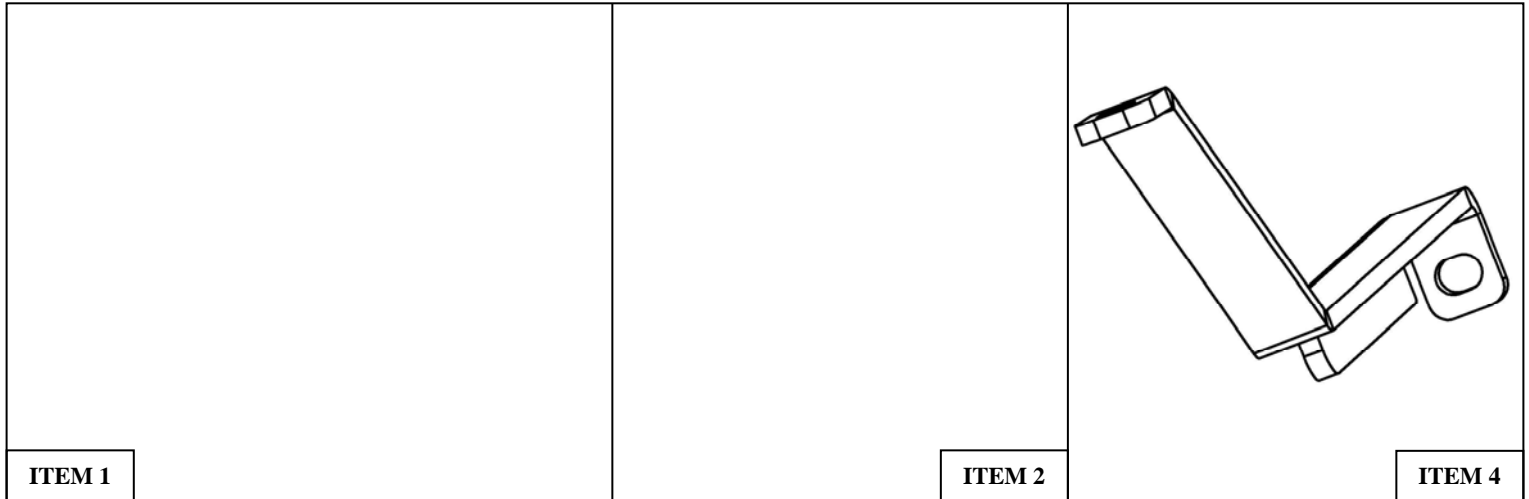

### CARE INSTRUCTIONS

- REGULAR WAXING IS RECOMMENDED. DO NOT USE ANY TYPE OF POLISH OR WAX THAT MAY CONTAIN ABRASIVES.
- STAINLESS STEEL PRODUCTS CAN BE CLEANED WITH MILD SOAP AND WATER. STAINLESS STEEL POLISH SHOULD BE USED TO POLISH SMALL SCRATCHES.
- GLOSS BLACK FINISHES SHOULD BE CLEANED WITH MILD SOAP AND WATER.



Westin Automotive Products, Inc.  
 320 W. Covina Blvd  
 San Dimas, Ca. 91773

Thank you for choosing Westin products  
 for additional installation assistance please call  
 Customer Service (800) 793-7846  
 www.westinautomotive.com

## PROCEDURE

1. Remove contents from box, verify if all parts listed are present and free from damage. Carefully read and understand all instructions before attempting installation.

**Failure to identify damage before installation could lead to a rejection of any claim.**

2. Under the hood of the vehicle remove screws and plastic push-pins to remove the grille. Once removed carefully pull off the grille. See **Figures 1 and 2.**

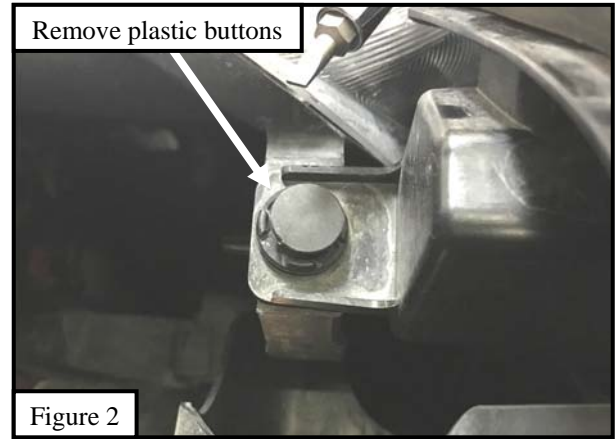

3. Insert (2) M10 bolt plates into the factory holes on the radiator support. See **Figure 3.**
4. Locate both straps (Items 4 & 5) and loosely secure to M10 bolt plates using the provided M10 hardware (Items 13-15). See **Figure 4.**

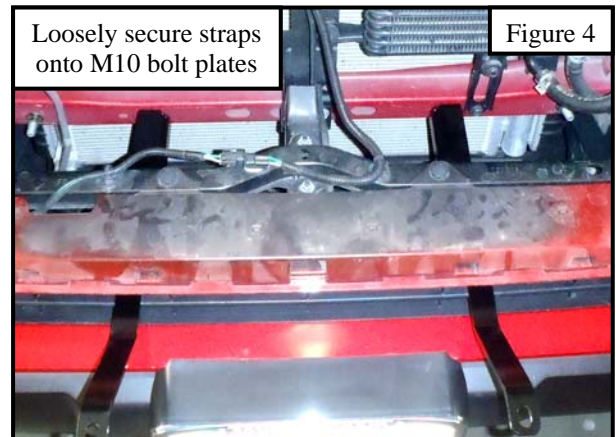
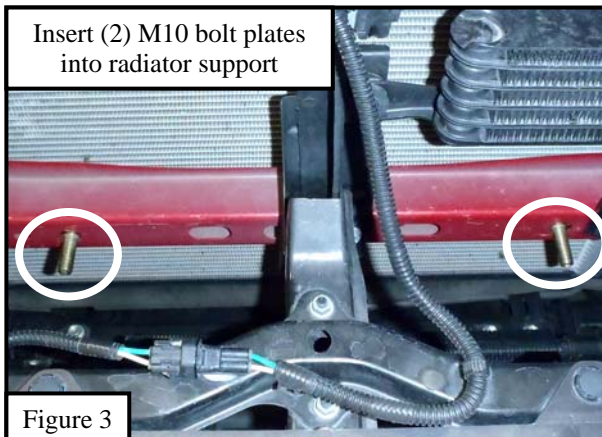

5. Cut a hole (4-1/2 in. x 1-3/8 in.) in both sides of the valance as shown **Figure 5.** And proceed to bracket installation.
6. Locate lower mounting locations for mount brackets (Items 2 & 3). See **Figure 6.**

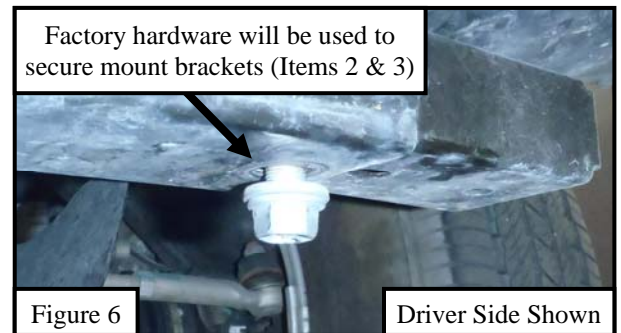
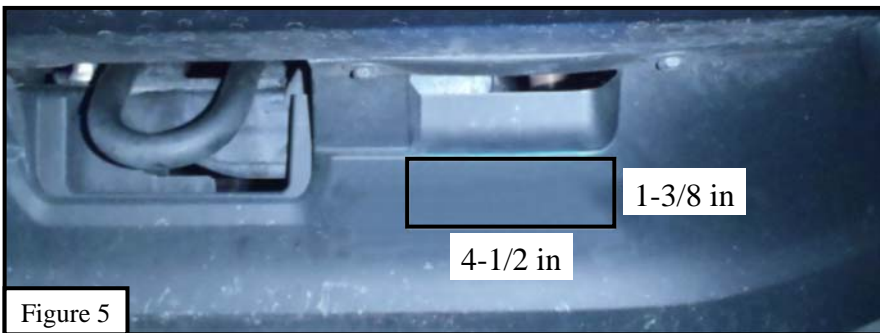

Westin Automotive Products, Inc.  
320 W. Covina Blvd  
San Dimas, Ca. 91773

- Loosely secure the mount brackets onto the mount location using the factory hardware located at the mounting location. See **Figure 7**.



- With assistance locate and lift the bull bar assembly and loosely secure onto the previously installed mount brackets using (2) M12 hex head cap screws, (2) M12 flat washers, and (2) M12 split lock washers. Using (2) 1/4-20" button head bolts, (4) 1/4" flat washers and (2) 1/4-20" hex lock nut to loosely secure the skid plate onto the mount brackets. See **Figure 8**. Using (2) 3/8-16" hex socket button head screws, (2) 3/8" flat washers and (2) 3/8" split lock washers to loosely secure the straps onto the bull bar assembly. See **Figure 9**.
- Align and adjust bull bar assembly as necessary and then torque all fasteners: M10 to 25-30 ft-lbs , M12 50-55 ft-lbs, 1/4" to 5-7 ft-lbs, and 3/8" to 15-20 ft-lbs.
- Reinstall the grille.

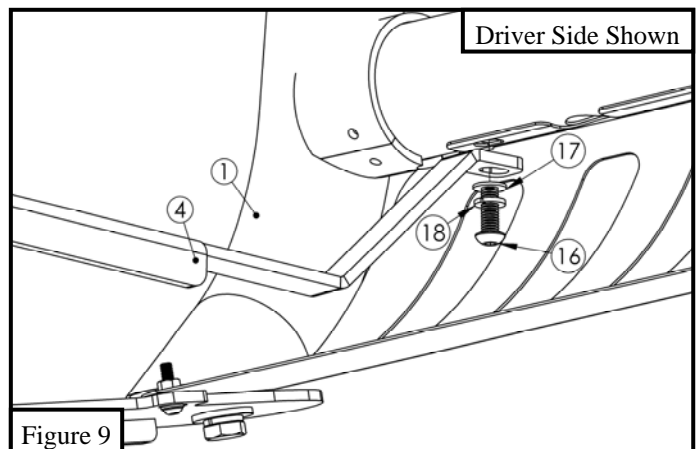
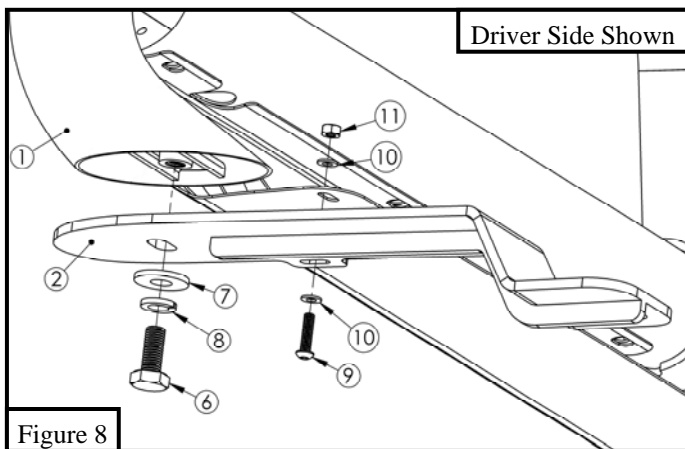

# Westin

SIGNATURE OF QUALITY

AUTOMOTIVE PRODUCTS, INC.



## WARNING



Failure to follow these instructions could lead to death, personal injury, and / or property damage.

### FASTENERS:

All Westin supplied fasteners must be utilized and installed in accordance with the installation instructions and apply torque to the specifications as defined. **DOUBLE CHECK ALL FASTENERS BEFORE INITIAL USE, AND PERIODICALLY IN THE FUTURE TO ENSURE PROPER FUNCTION AND SAFETY.**

### DRILLING:

Most Westin products do not require drilling for installation. If drilling is defined as required, use caution when drilling a vehicle. **FAILURE TO REVIEW AN AREA TO BE DRILLED MAY RESULT IN PERSONAL INJURY AND/OR INJURY TO OTHERS AS WELL AS VEHICLE DAMAGE.**

### EYE PROTECTION:

**ALWAYS WEAR SAFETY GLASSES OR GOGGLES DURING THE INSTALLATION PROCESS TO AVOID PERSONAL INJURY.**

### MAXIMUM TOWING/CARRYING CAPACITY:

The Westin Receiver Hitches will have a visible tow rating label affixed directly on the product. User should never exceed the vehicle manufacturers maximum tow and weight rating regardless of the capacity of the hitch. **FAILURE TO FOLLOW THESE GUIDELINES WILL VOID THE WESTIN WARRANTY AND MAY RESULT IN PERSONAL INJURY AND/OR INJURY TO OTHERS AS WELL AS VEHICLE DAMAGE.**

**Westin**  
SIGNATURE OF QUALITY

Westin Automotive Products, Inc.  
320 W. Covina Blvd  
San Dimas, Ca. 91773