



B&W Trailer Hitches
 1216 Hawaii Road / PO Box 186
 Humboldt, KS 66748
 P:800.248.6564
 F:620.869.9031

See Limited Lifetime Warranty at
bwtrailerhitches.com/warranty

NOTE: *We recommend reading instructions before beginning the installation.*

GM OEM Mount System Slider Hitch Installation Instructions

20,000 LBS. TRAILER WEIGHT
5,000 LBS. TRAILER TONGUE WEIGHT

Call or Email us for Installation Support
hitches@turnoverball.com www.bwtrailerhitches.com

Model 3775

Fits 2020 GM Puck System

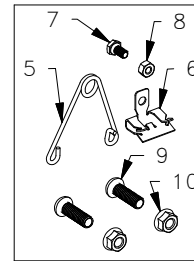
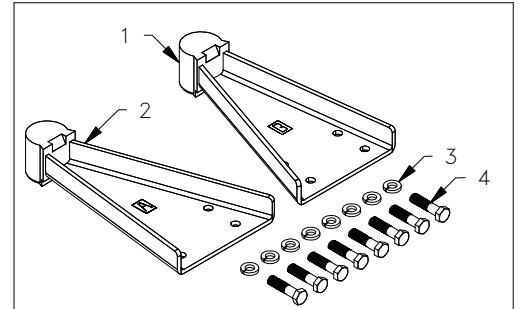
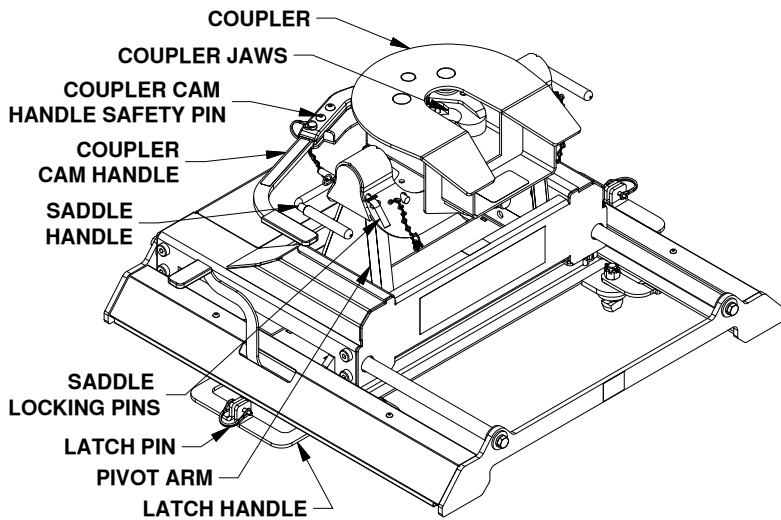

BASE BOLT BAG (RVB3770)		
ITEM	DESCRIPTION	QTY
1	Pivot Arm A	1
2	Pivot Arm B	1
3	1/2" Split Lock Washers	8
4	1/2" X 2" Cap Screw	8

COUPLER BOLT BAG (RVC3006)		
ITEM	DESCRIPTION	QTY
5	Wire Torsion Spring	1
6	Mounting Clip	1
7	1/4" X 1/2" Cap Screw	1
8	1/4" Finish Nut	1
9	3/8" Button Head Cap Screw	2
10	3/8" Lock Nut	2

REQUIRED TOOLS

Installation of the Companion hitch requires a large torque wrench capable of measuring 80 ft-lbs, a 3/4" socket, a 7/16", and 9/16" socket or wrench, a 7/32" allen wrench, a pair of needle-nose pliers and a hammer.

⚠️ WARNING

Failure to comply with the safety information in these instructions could result in serious injury or death.

- ⚠️** Read all installation and operating instructions along with all labels before using this product.
- ⚠️** Adding components to the chassis of any vehicle can be hazardous. There is potential for damage to vehicle, injury from tool usage and many other hazards. This installation must be completed by someone who is aware of the hazards involved. This person must be knowledgeable of proper safety procedures for a vehicle installation of this nature, and for usage of the equipment required to perform the installation.
- ⚠️** A visual inspection of the hitch should be performed before each time you tow. Regularly check that all pinned connections are secure, and that all bolted connections are at the correct torque specification. Check for cracks or damage to the hitch. Do not tow with the hitch if cracks or damage outside of normal wear is found. Towing with a hitch that has cracks or damage could result in damage to the tow vehicle, trailer, towing components or loss of attachment between the tow vehicle and trailer.
- ⚠️** Do not exceed tow or tongue rating of coupler, tow or tongue rating of hitch, or tow or weight ratings of truck or trailer. See vehicle and trailer manufacturer information for ratings. Exceeding these ratings may cause damage to towing components or loss of attachment between the trailer and truck.
- ⚠️** Additional caution must be used when towing a wedge car trailer. Towing stability greatly depends on keeping the center of gravity as low as possible. Load heavy cars over the axles. Never tow with a single car on the front of the trailer. When towing a wedge car trailer, never exceed speeds that are reasonable for the roadway conditions (e.g. turns, going around a curve, etc.). Failure to account for proper trailer center of gravity and speeds that are reasonable for the roadway conditions may cause damage to the truck, trailer, towing components, and loss of attachment between the truck and trailer.
- ⚠️** Do not modify this product in any manner. Doing so could alter its integrity and lead to a loss of attachment between the trailer and the tow vehicle.
- ⚠️** Without proper knowledge, towing can be a dangerous activity. Understand all the risks involved with towing before proceeding. For information on towing safety, see **"The Trailer Handbook: A guide to Understanding Trailer and Towing Safety"** from the *National Association of Trailer Manufacturers*, www.NATM.com and your trailer manufacturer's owner's manual.
- ⚠️** Components of the hitch are heavy and cumbersome to handle. Use proper lifting techniques when moving and handling parts.

PREPARING TO INSTALL

- Remove any debris and/or obstructions from the truck bed, this includes any plastic caps which may be over the attachment points. It may also be necessary to remove the plastic grommets from around the mounting points in order to fully seat the base down to the truck.

CAUTION: Lifting the slider base under the sheet metal covers may cause damage to the base, grip base by end rail supports to lift, see Figure B1.

WARNING: Whenever the slider base is being moved, the slider handle must be in the locked position, and the carriage must be unable to slide, see Figure A1. Failure to ensure that the handle is in the locked position can lead to property damage, or serious injury.

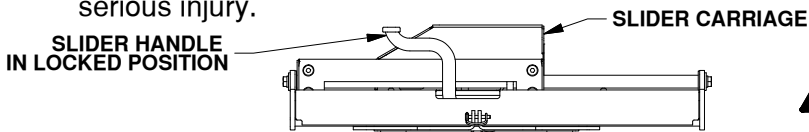

Figure A1: View of driver side of Slider Base.

INSTALL SLIDER BASE

WARNING: The latch cams and handles must be adjusted to fit the tow vehicle. Failure to properly adjust the cams and handles may result in property damage and/or personal injury.

1. Place Base. Remove the latch pins from each side of the base and rotate the handles out, see Figure B1. Place the base over the attachment points and carefully lower it until the latch cams pass through the floor and the base rests flat against the top of the attachment points.

2. Prepare to adjust latch tension. Once the base is in place, remove the cotter pins from each of the four castle nuts. Engage the cams with each attachment point by turning the latch handles back to their locked position, see Figure B2. If a handle will not turn easily, loosen the castle nut until the cam will freely turn and engage the attachment point.

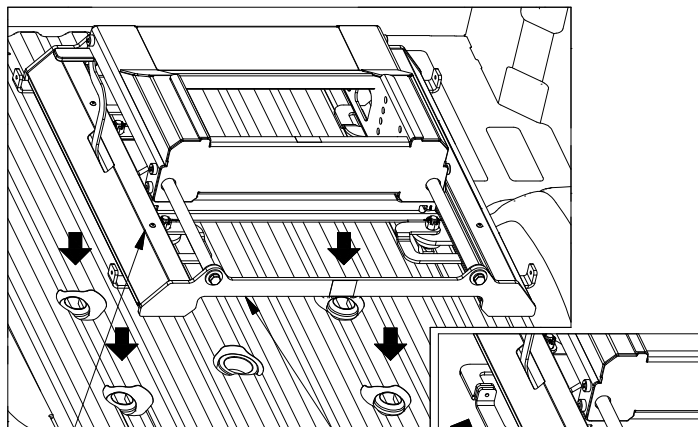

Figure B1: View of unlatched base.

END RAIL SUPPORTS
SHEET METAL COVERS

Figure B2: View of closed latch handle.

3. Adjust the tension in the latch handle, for parts list and visual guide refer to Figures B3 and B4.

With the handles in the latched position, tighten the castle nut until snug to increase the tension on the latch. Rotate the latch handle open and closed. Tighten the castle nut slightly and rotate the handle open and closed again. Repeat this process until you feel the cam engage the attachment point while closing the handle. The handle is set at the proper tension when there is friction between the cam and attachment point but the handle can still be closed by hand without bumping, tapping, or otherwise forcing the handle closed.

NOTE: Access to all four castle nuts requires that the slider carriage be moved between the towing and maneuvering positions. See Figures H3 and H4 on page five for instructions on moving the carriage.

WARNING: Setting latch handle tension so that excessive force is required to close the latch handles may result in property damage and/or personal injury.

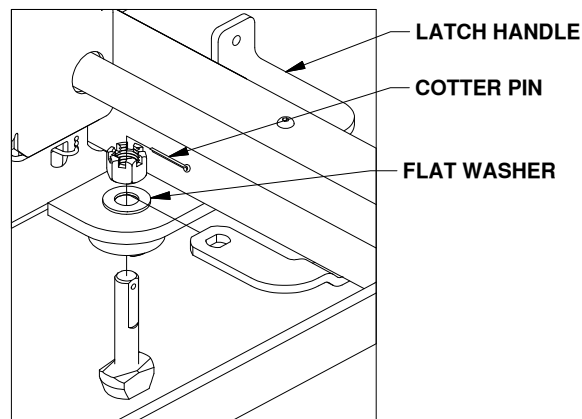

Figure B3: List of latch parts.

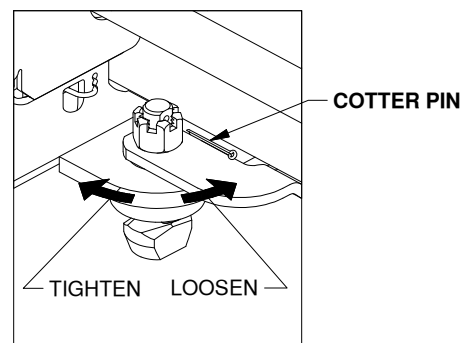

Figure B4: View of base leg.

NOTICE: Verify latch tension each time the Companion base is placed in a truck, and periodically before towing.

4. Replace latch pins. With the base firmly held down and each latch handle closed, replace the latch pins removed in Step 1.

INSTALL PIVOT ARMS

- 1. Mount arms.** Mount the pivot arms using one of the six different locations illustrated in Figure C1. These six locations allow flexibility in coupler height and distance from the cab. Choose a location so that your trailer will be as level as possible and have adequate turning clearance while in the towing position (with the slider in the forward position). See warnings after step 2.

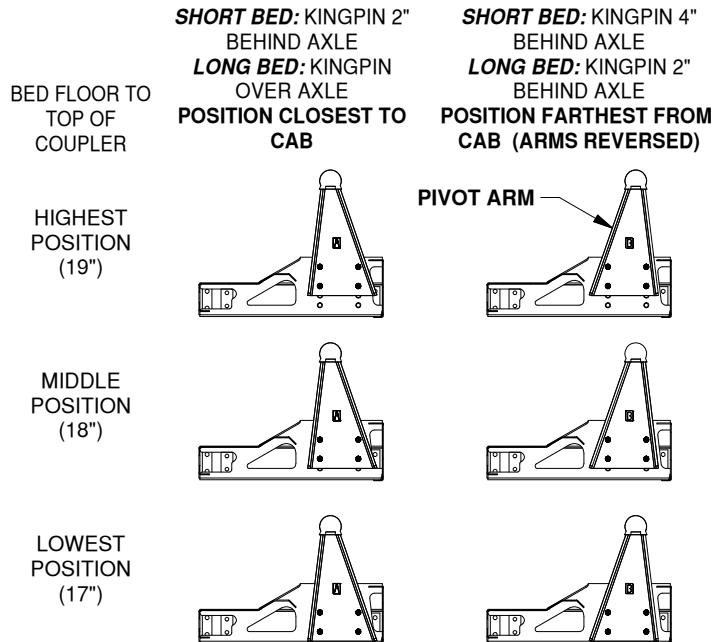
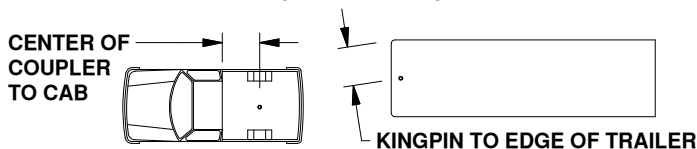

Figure C1: Cut away view of slider carriage arm positions.

- 2. Secure arms.** With the flat side of the pivot arm flat against the bolt plate in the slider base, install four 1/2" x 2" bolts and four 1/2" split lock washers for each arm. Torque each bolt to 80 ft-lbs.

⚠ WARNING: Check the clearance between the truck cab and the trailer in both the towing position and the maneuvering position. Compare the measurement taken from the center of the Slider Coupler to the cab, to the measurement taken from the center of the king pin to the farthest forward corner point of the trailer. These measurements will allow you to see how much clearance you will have between the cab and the trailer while towing and turning.



⚠ WARNING: Check the clearance between the bed side and the underside of the front of the trailer and to allow adequate clearance for the pitch and roll of the trailer while towing.

⚠ WARNING: Parts of the trailer may strike the tailgate when sliding the companion rearward. Check the clearance between the tailgate and trailer components such as the trailer tongue or pin box. Failure to check clearance may cause property damage.

INSTALL LEVELING KIT

- 1. Assemble kit.** Locate the 1/4" cap screw and nut, along with the wire tension spring and mounting clip. Pass the 1/4" cap screw through the mounting clip and the wire spring, as shown in Figure D1. Thread the 1/4" lock nut onto the 1/4" cap screw. Tighten the lock nut just enough that the spring will stay in place but will still be able to rotate around the bolt if needed, see Figure D2.

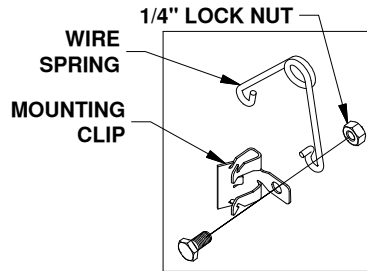

Figure D1: Leveling kit parts.

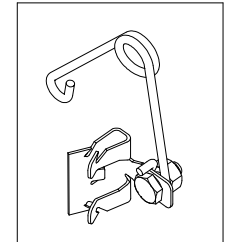

Figure D2: Assembled leveling kit.

- 2. Attach kit.** Locate the flange which will be closest to the truck cab on the driver side pivot arm, see Figure D3. The clip should be placed so that when the spring's coil is in line with the edge of the arm there will be 1/2" of clearance between the bottom of the rubber bumper and the top of the spring, see Figure D4. Drive the clip securely onto the flange with a hammer.

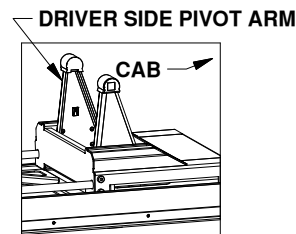

Figure D3: Base view.

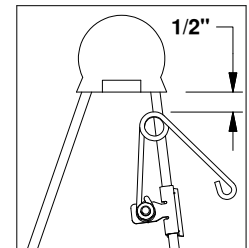

Figure D4: Driver side pivot arm.

INSTALL COUPLER HANDLE

1. **Open coupler.** Locate the two 3/8" x 1-1/4" button head cap screws and the two 3/8" flanged lock nuts provided in a bolt bag. Pull out the coupler arm and pin it with the safety locking pin near the base of the arm as shown in Figure E1.

CAUTION: Pulling the arm out away from the coupler creates a pinch point. Use caution when installing the handle to avoid injury.

2. **Secure handle.** Using the button cap screws and the lock nuts, attach the coupler handle to the arm and tighten, see Figure E1. Pull out the coupler cam handle safety pin.

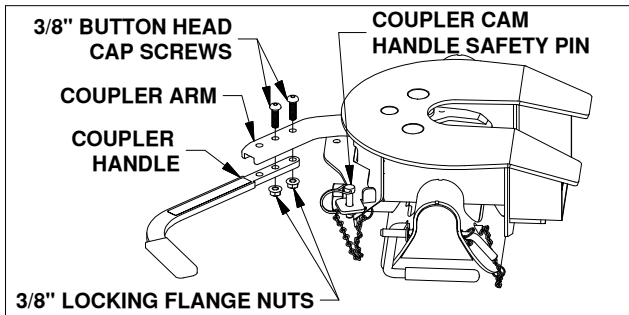

Figure E1: View looking down at side of coupler head.

INSTALL COUPLER

1. **Place coupler.** Lubricate the polyurethane bushings on top of pivot arms with high grade lithium grease (available at your local hardware/automotive store). Place the coupler over the pivot arms. (The saddle handles should be parallel with the Slider Base in the latched position.) Place the saddle lock pins through the saddle, then insert the hair pins through the holes in the end of the saddle lock pins to secure the coupler to the pivot arms.

2. **Set coupler angle.** Adjust the resting angle of your coupler plate by rotating the spring on the driver side pivot arm. Pulling the top of the spring away from the cab will increase the angle of the coupler plate. Set the angle of the coupler so that head will tilt away from the cab when coupling, see Figure F1. Tighten the 1/4" nut once the spring's orientation is set.

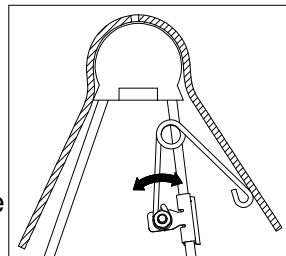

Figure F1: Cutaway view of driver side pivot arm and saddle.

ATTACHING TRAILER

Remove the coupler cam handle safety pin and rotate the cam handle to the open position. Adjust the height of the 5th wheel trailer so that the king pin plate is slightly lower than the top of the coupler. Back the truck towards the trailer, centering the trailers king pin in the Coupler, until the king pin has engaged the jaws. Ensure that the Coupler cam handle has completely closed before inserting the cam handle safety pin through the cam handle and the coupler. Hook up brake and lighting connections before towing.

PULL TEST

Have the truck stationary with the emergency brake on, the trailer wheels blocked and landing gear still resting firm on the ground supporting the weight of the trailer. Make sure no one is between the truck and trailer, return to the cab of the truck. Release the emergency brake and apply the trailer brakes. Try to pull the trailer forward with the truck. If the trailer is properly hooked up, the wheel blocks and trailer brakes should not allow the truck to move forward. If trailer is not hitched correctly, the trailer will separate from the truck. However, with the landing gear resting firmly on the ground, it will support the trailer and not allow it to drop or fall on the truck sides.

UNATTACHING TRAILER

Lower landing gear and block the trailer wheels. Raise the trailer until the tongue weight is removed from the truck. Then, unpin the Coupler handle and rotate to the open position to unlatch the jaws. If the jaws do not open, readjusting the landing gear may relieve pressure and allow them to open. Use the safety pin to lock the handle in the open position and when you are sure that the landing gear will support the trailer, move the truck forward to release the jaws from the kingpin. The jaws will always open when the pressure of the trailer is taken off the Coupler as the truck pulls away.

UNINSTALL HITCH

To uninstall the Companion hitch, remove the saddle lock pins, grab the saddle handles and lift to remove the coupler from the pivot arms. To remove the Companion base, remove the latch pins from each base leg and turn the handles. Carefully lift and position the base out of the attachment points.

NOTICE: Base latch handle tension and all bolted connections should be checked regularly. The latches must have the proper resistance when rotating, and bolts must have proper torque. Always perform a visual inspection before towing.

WARNING: Do not use the Companion 5th wheel hitch with any device that changes the location of the king pin pivot point. The king pin on your trailer must rotate in the jaws of the Companion Coupler, see Figure F3. Preventing the king pin from rotating within the jaws of the Companion Coupler with a wedge, see Figure F4, or any other device, such as a Reese Sidewinder® or Reese Revolution®, could result in property damage, serious injury or death.

Reese® is a registered trademark of Cequent Performance Products.

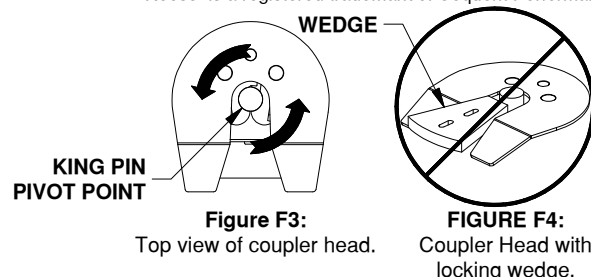

SLIDER OPERATION

⚠ WARNING: Use extreme caution when moving the truck and trailer in the maneuvering position. Never exceed 5 mph (roughly walking speed) when in the maneuvering position, doing so may result in property damage, serious injury or death.

CAUTION: Use of the slider mechanism should only be attempted while on smooth flat terrain.

⚠ WARNING: The maneuvering position is only intended for parking maneuvers and not for towing. Using the slider in any other capacity could result in serious injury or death.

⚠ WARNING: Never hold on to the handle or force it in any direction while the truck is moving. Failure to stand clear of the handle when the slider is in operation could result in serious injury.

Moving from towing position to maneuvering position. (Figure H3 to H4)

1. While the trailer is coupled, set the trailer brakes and/or chock the trailer wheels.
2. Pull the handle toward the rear of the truck to move it to the unlocked position, shown in Figure H2.
3. Pull the truck forward slowly until the handle falls and is in the locked position, shown in Figure H1.
4. Release the trailer brakes, un-chock the trailer and maneuver the trailer as needed.

Moving from the maneuvering position to the towing position. (Figure H4 to H3)

5. Once the trailer is satisfactorily positioned, set the trailer brakes and/or chock the trailer wheels.
6. Pull the handle toward the rear of the truck to move it to the unlocked position, shown in Figure H2.
7. Move the truck slowly in reverse until the handle falls and is in the locked position, shown in Figure H1.
8. Release the trailer brakes and un-chock the trailer.

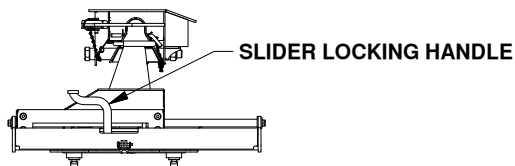

Figure H1: Side view of Slider Base. LOCKED HANDLE POSITION

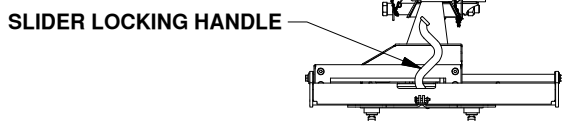

Figure H2: Side view of Slider Base. UN-LOCKED HANDLE POSITION

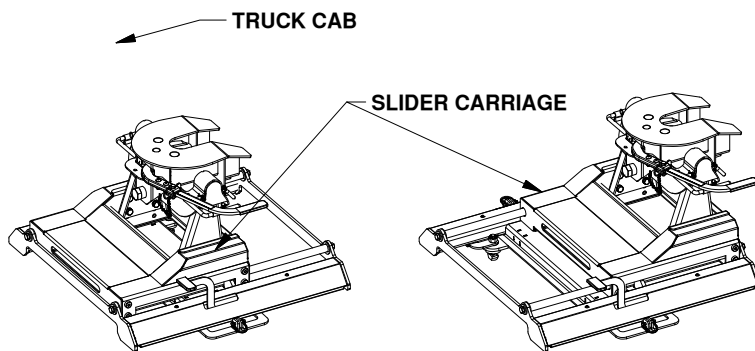

Figure H3: View of Slider Base with the Carriage in a forward position. TOWING POSITION

Figure H4: View of Slider Base with the Carriage in a back position. MANEUVERING POSITION

HELPFUL TIPS:

Approximately 15%-25% of the trailer weight should be on the hitch.

The height of the king pin box and pivot arms should be adjusted so that the trailer is approximately level for towing.

Allow adequate clearance between the bed side and the underside of the front of the trailer for pitch and roll of the trailer.

Lubricate top surface of coupler with multi-purpose automotive type chassis grease or use a nylon lube plate to provide a lubricated surface.

Grease jaws with multi-purpose automotive type chassis grease.

Grease the saddle through the grease zerk approximately every six months with multi-purpose grease. This allows the coupler to pivot freely, see Figure J1.

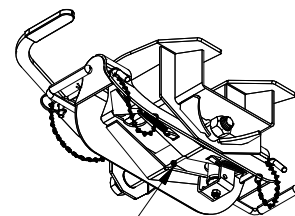

Figure J1: Underside view of Coupler Head.