



B&W Trailer Hitches

1216 Hawaii Rd/ PO Box 186

Humboldt, KS 66748

P:800.248.6564

F:620.869.9031

Call or Email us for Installation Support

hitches@turnoverball.com www.bwtrailerhitches.com

NOTE: We recommend reading instructions before beginning the installation.

Universal Mounting Rail Installation Instructions

Model 3200

HARDWARE KIT	QTY:
1 - Carriage bolt 1/2-13 x 2"	10
2 - Mounting rail	2
3 - Slotted spacer	10
4 - Block spacer	2
5 - Short mounting bracket	2
6 - Flat washer	10
7 - Lock washer	18
8 - Finish nut	18
9 - Knurled bolt	8
10 - Long mounting bracket	2
11 - Carriage bolt 1/2-13 x 4-1/2"	2
12 - Tube spacer	2
13 - Fish wire (Not shown)	2

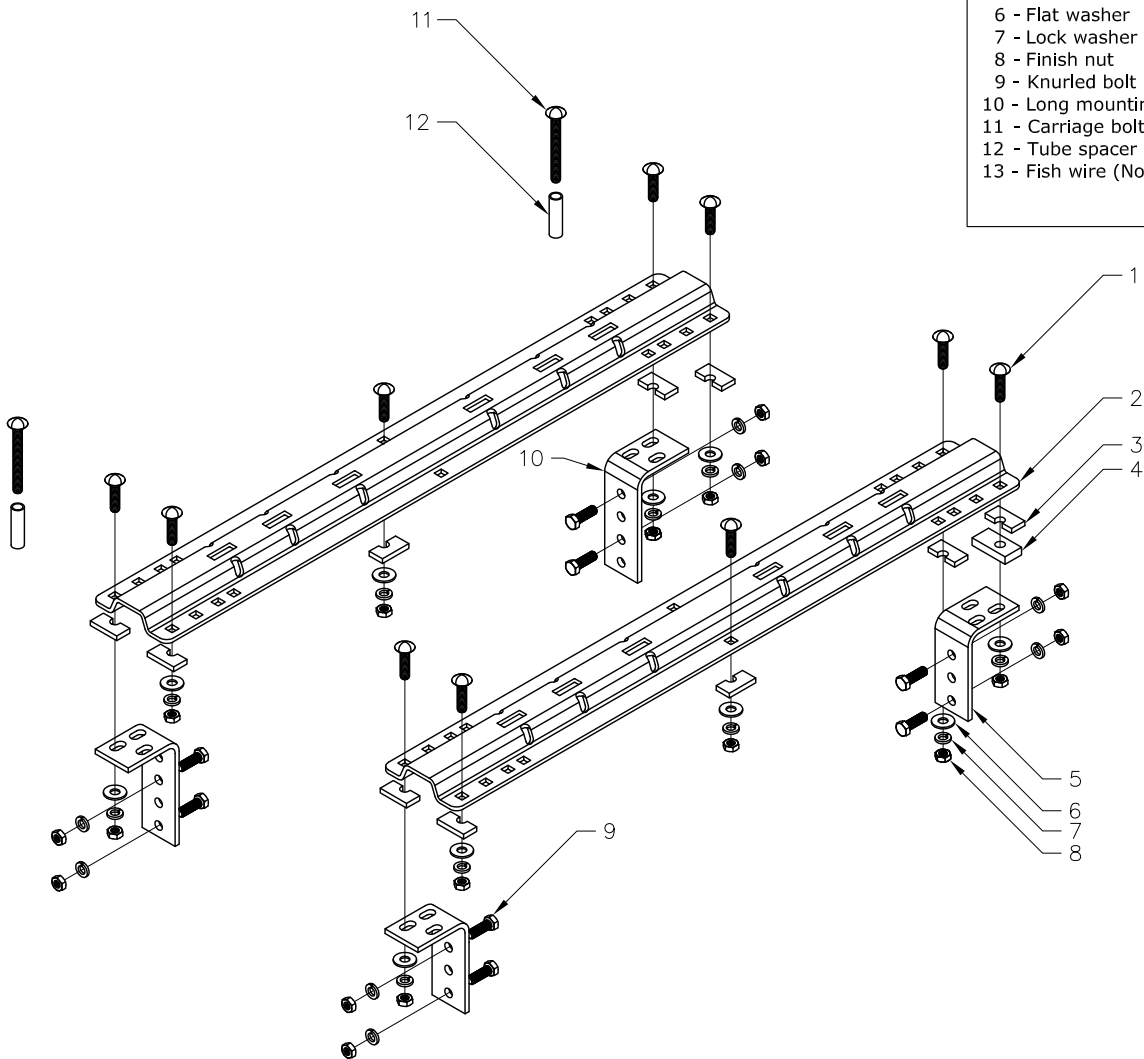

Note: Some truck models require supplemental kits to install. see page 9 for complete list.

TOOLS REQUIRED FOR INSTALLATION

3/16" DRILL 17/32" DRILL 1" DRILL (Some Dodge applications only)
3/4" SOCKET AND OPEN END WRENCH 100 lb-ft TORQUE WRENCH "C" CLAMPS

1. The following instructions provide detailed information for anchoring the B&W Patriot. Carefully read all instructions and double check measurements before drilling any part of the truck bed or frame.

Warning: The owner is responsible for the installation of this product. These instructions are guidelines only. Always measure both the truck and trailer prior to installation of the hitch to check for cab and bumper turning clearance.

Warning: On truck beds which are 6' or less in length precautions may be needed to prevent damage to the truck. On a long bed installation the center of the hitch is a minimum of 52" to the back of the cab. Short bed installations (trucks with a minimum of 38" from the cab to axle center) will require a trailer pin box extension of 13" or more to achieve a safe turning clearance.

2. Raise the rear of the truck to allow jack stands to be placed under the rear spring hanger brackets of the truck. Be sure the truck is properly blocked and restrained to prevent movement of the truck during installation. Failure to do so may result in the truck falling, causing serious injury or death.

3. Do not install mounting rails over plastic liners. Plastic liners must be removed or cut out of the way before installation. Base rails may be installed over a spray in liner. Consult installer for recommended curing time.

4. Only use hardware supplied with installation kit. All bolts and nuts are grade 5 unless otherwise specified. All hardware will not be used on all applications.

5. If your vehicle is not covered by these instructions, install each base rail so that it is connected to the vehicle frame by at least two frame brackets. Each frame bracket must be attached to the frame by at least two bolts or welding.

6. Measurements for laying out the base rails are provided for most truck installations. These measurements are given for the distance between the rearmost edge of the base rail to the end of the truck bed, see figure 2 below.

7. Layout the base rails so they are square with each other and centered between the wheel wells. Measuring two diagonal lines until they are the same will ensure the rails are square, see figure 2 below.

8. Drill the 10 mounting holes, locations for your individual application will vary. For each hole first drill a 3/16" pilot hole and then finish with a 17/32" drill. Always use sharp drill bits. Install 1/2" carriage bolts into the drilled holes. Use 5/16" thick slotted spacers above or below bed to fill corrugation in bed floor. (Toyota Tundra will require additional spacer kit #3206 to be used with spacers supplied in kit 3200. See Toyota Tundra application guide for details.)

9. Under the truck bed, install the long mounting brackets onto the front rail carriage bolts and the short mounting brackets onto the rear rail carriage bolts; these can be interchanged as needed. Use washers, lock washers, and hex nuts, to secure the carriage bolts to the mounting brackets and to the bottom of the truck bed.

10. For rib neck bolts use a 17/32" drill only, failure to do so may cause bolt to fail. For each bracket drill two 17/32" holes through the truck frame. Drill locations can be located by using the mounting bracket as a guide. Select holes which will give the greatest spread between bolts. To attach mounting brackets to truck frame, install eight 1/2"-13 x 1-3/8" ribbed neck bolts, lock washers, and hex nuts. Install the ribbed neck bolts so that the threads point away from the center of the truck. Tighten each nut until the bolt head seats. Lubrication of the knurls of all rib neck bolts is recommended. Do not lubricate threads as it may cause bolts to fail.

11. Unless otherwise stated, torque all nuts to 85 lb-ft.

12. A pull wire is provided to pull rib neck bolts through frame as needed per application.

Drill locations will vary. See individual installation for location

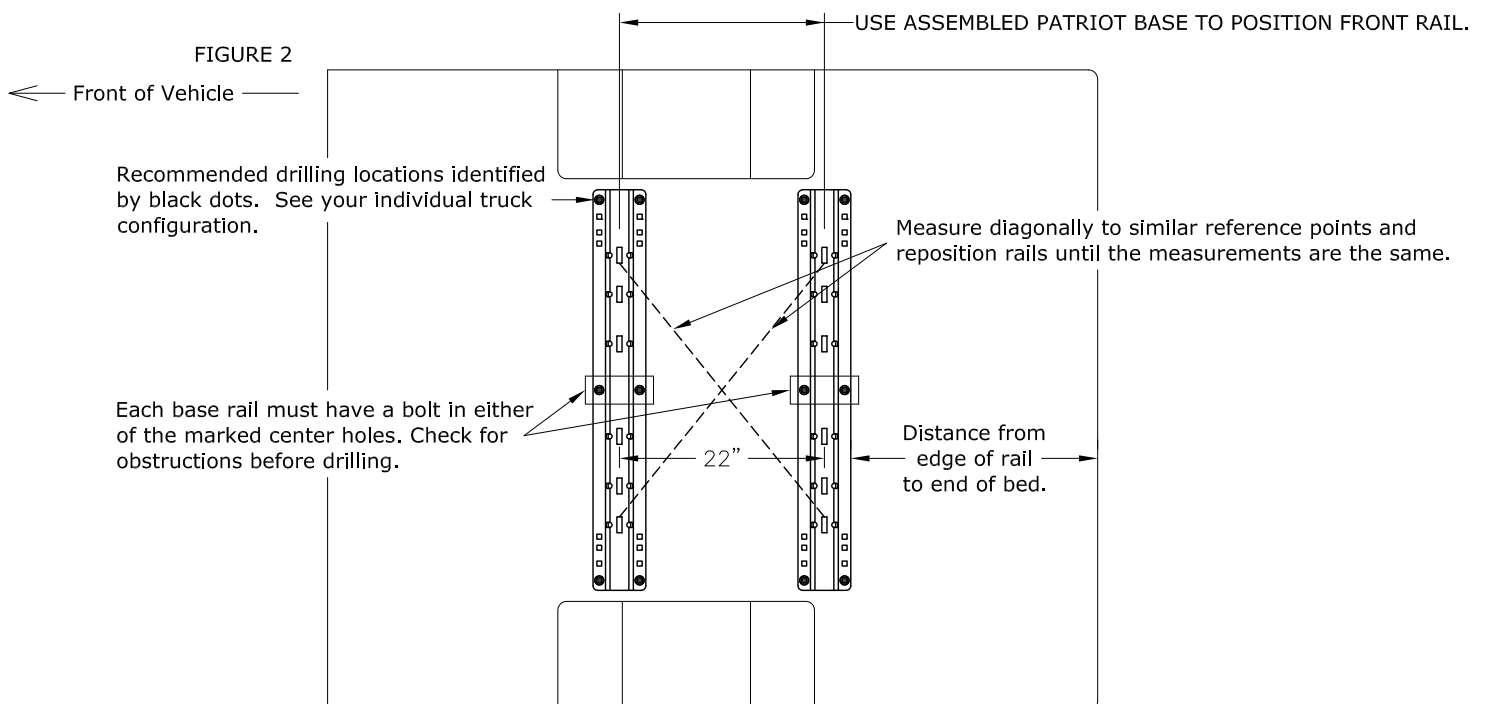

CHEVROLET/GMC 2011 to 2015, 2500 HD & 3500 HD Silverado and Sierra

Before beginning, find the parallel rows of bed sill spot welds in bed of the truck. No drilling should be done in the 4" space between parallel rows of spot welds where the bed sill is located.

Only one of the two holes in the center of each of the base rails is necessary, check for obstructions before drilling.

NOTE:
For ease of installation, Grade 5, 1/2" X 13 cap screws, and washers may be used in place of the 1/2" carriage bolts

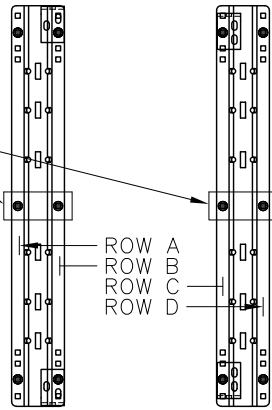

TOP VIEW

DISTANCE FROM EDGE OF RAIL TO END OF BED

8' BED: 29-3/4"

5'8" & 6'6" BED: 25-1/4"

CAUTION:

Read pages 1-2 of these instructions before starting installation. Failure to do so could result in significant vehicle damage!

CAUTION:

Check for obstructions before drilling. Failure to do so could result in damaged fuel or brake lines, structural members, etc. B&W does its best to communicate tow vehicle manufacturer changes; however, it is ultimately the responsibility of the installer to prevent damage due to installation.

WARNING:

Do not install on a truck with a 5'8" long bed unless provision has been made to prevent the trailer from hitting the cab of the truck.

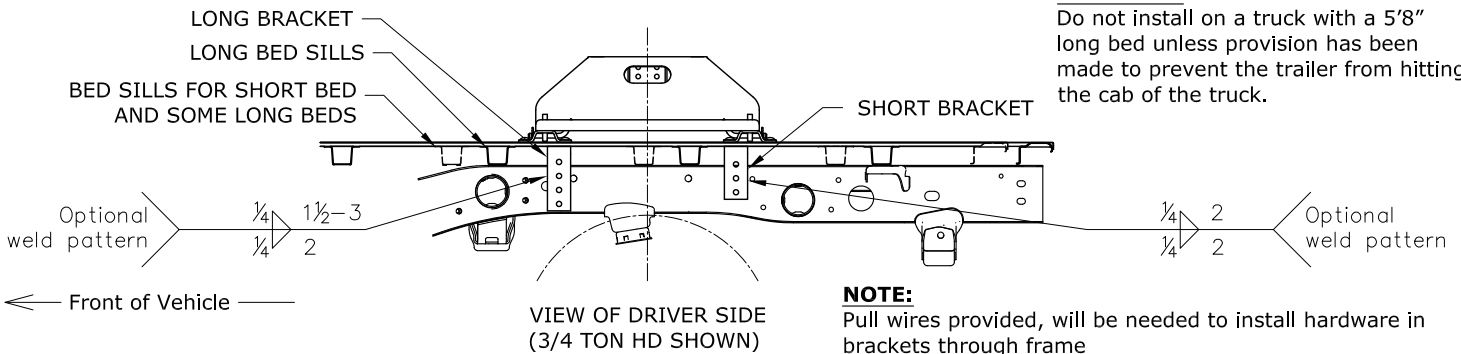

NOTE:

Pull wires provided, will be needed to install hardware in brackets through frame

GMC 1999 Silverado, Sierra (not Sierra Classic) models. CHEVROLET/GMC 2000 to 2010 2500 HD and 3500 HD. 2000 to 2018 1500 Silverado and Sierra & 2019 Limited

Before beginning, find the parallel rows of bed sill spot welds in bed of the truck. No drilling should be done in the 4" space between parallel rows of spot welds where the bed sill is located.

Only one of the two holes in the center of each of the base rails is necessary, check for obstructions before drilling.

In later model trucks exchange the forward long brackets from one side to the other and install the driver side long bracket in row B. This will add clearance for the a brake cable hanger.

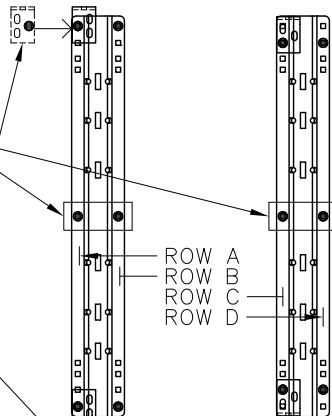

TOP VIEW

DISTANCE FROM EDGE OF RAIL TO END OF BED

8' BED: 30"

5'8" & 6'6" BED: 25-1/8"

CAUTION:

Read pages 1-2 of these instructions before starting installation. Failure to do so could result in significant vehicle damage!

CAUTION:

Check for obstructions before drilling. Failure to do so could result in damaged fuel or brake lines, structural members, etc. B&W does its best to communicate tow vehicle manufacturer changes; however, it is ultimately the responsibility of the installer to prevent damage due to installation.

WARNING:

Do not install on a truck with a 5'8" long bed unless provision has been made to prevent the trailer from hitting the cab of the truck.

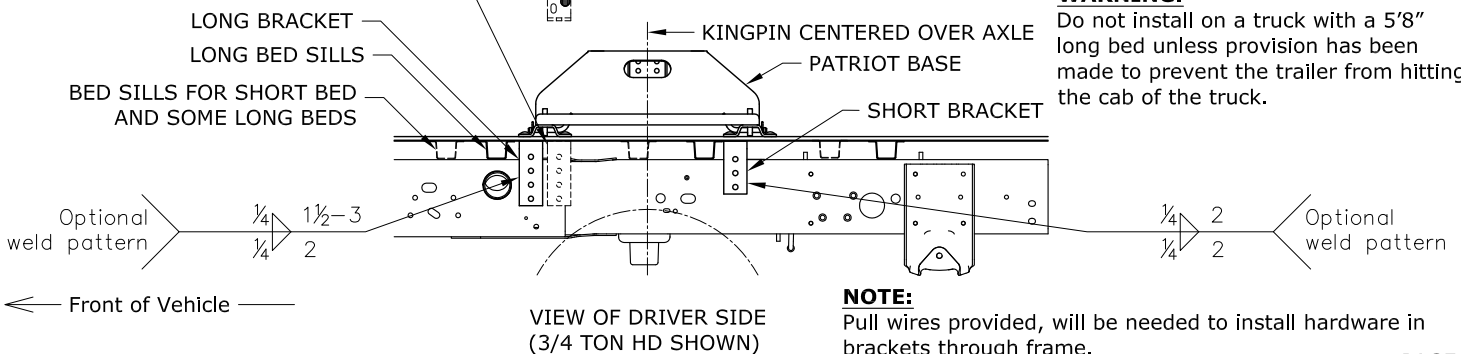

NOTE:

Pull wires provided, will be needed to install hardware in brackets through frame.

CHEVROLET/GMC 1988-1998 / 1992-1998 4-DOOR / 1999 SILVERADO. SIERRA CLASSIC
(WITH TAPERED FRAME) (RED TURN SIGNALS)

To begin, find the parallel rows of bed sill spot welds in bed of the truck. No drilling should be done in the 4" space between parallel rows of spot welds where the bed sill is located.

Only one of the two holes in the center of each of the base rails is necessary, check for obstructions before drilling.

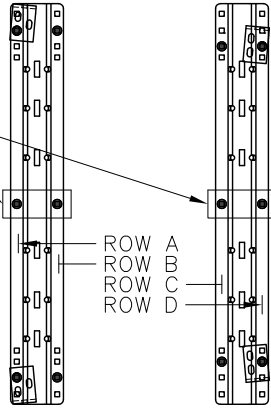

TOP VIEW

DISTANCE FROM EDGE OF RAIL TO END OF BED

LONG BED: 30-15/16"

SHORT BED: 26-3/16"

CAUTION:

Read pages 1-2 of these instructions before starting installation. Failure to do so could result in significant vehicle damage!

CAUTION:

Check for obstructions before drilling. Failure to do so could result in damaged fuel or brake lines, structural members, etc. B&W does its best to communicate tow vehicle manufacturer changes; however, it is ultimately the responsibility of the installer to prevent damage due to installation.

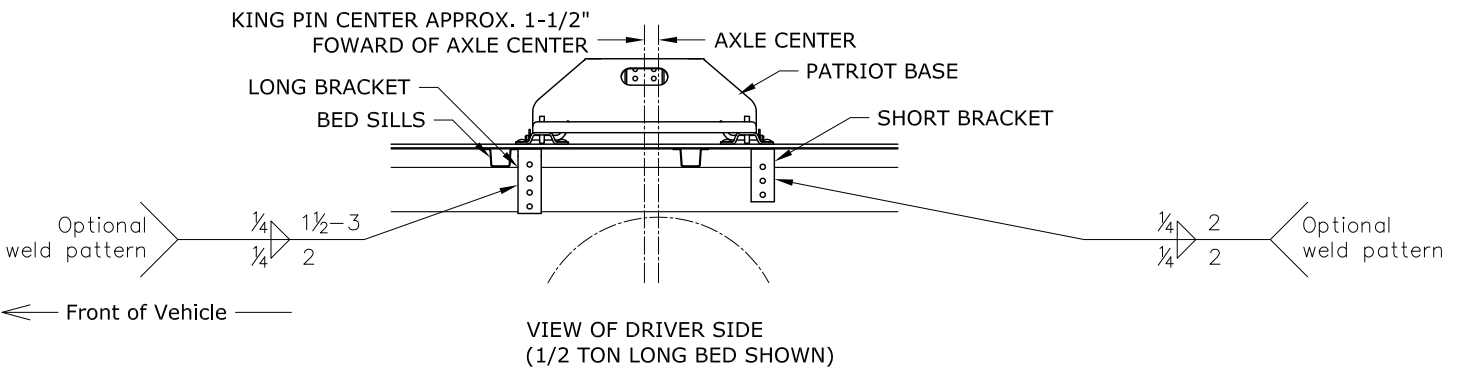

VIEW OF DRIVER SIDE
(1/2 TON LONG BED SHOWN)

CHEVROLET 1973 to 1987 / 1973 to 1992 4-door (GMC) (34" Straight, with Outside Shock Absorbers)

Drill through bed and truck frame.

Only one of the two holes in the center of each of the base rails is necessary, check for obstructions before drilling.

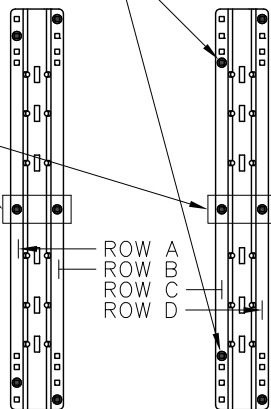

TOP VIEW

DISTANCE FROM EDGE OF RAIL TO END OF BED

LONG BED & SHORT BED: 34-7/8"

CAUTION:

Read pages 1-2 of these instructions before starting installation. Failure to do so could result in significant vehicle damage!

CAUTION:

Check for obstructions before drilling. Failure to do so could result in damaged fuel or brake lines, structural members, etc. B&W does its best to communicate tow vehicle manufacturer changes; however, it is ultimately the responsibility of the installer to prevent damage due to installation.

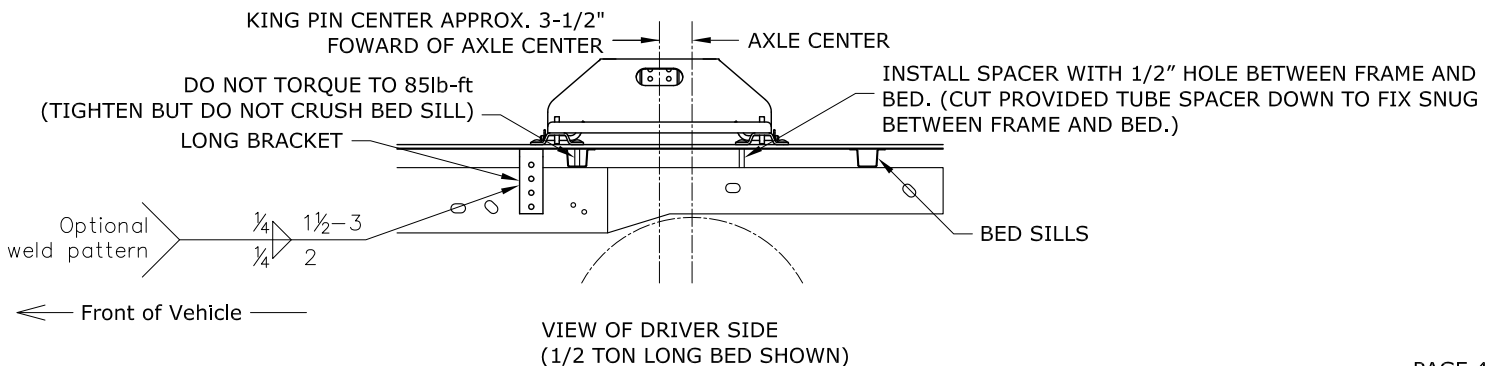

VIEW OF DRIVER SIDE
(1/2 TON LONG BED SHOWN)

CHEVROLET 1973 to 1987 / 1973 to 1992 4-door (GMC) (34" Straight, with Inside Shock Absorbers)

Only one of the two holes in the center of each of the base rails is necessary, check for obstructions before drilling.

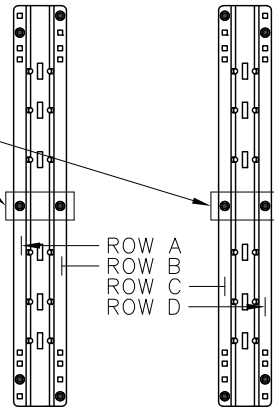

TOP VIEW

DISTANCE FROM EDGE OF RAIL TO END OF BED

LONG BED & SHORT BED: 34-7/8"

CAUTION:

Read pages 1-2 of these instructions before starting installation. Failure to do so could result in significant vehicle damage!

CAUTION:

Check for obstructions before drilling. Failure to do so could result in damaged fuel or brake lines, structural members, etc. B&W does its best to communicate tow vehicle manufacturer changes; however, it is ultimately the responsibility of the installer to prevent damage due to installation.

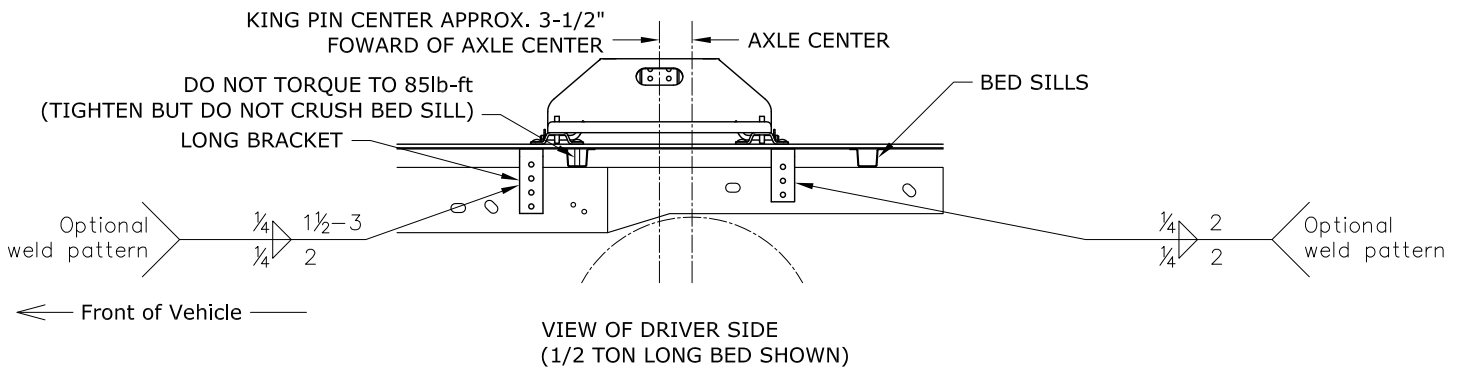

VIEW OF DRIVER SIDE
(1/2 TON LONG BED SHOWN)

FORD F-150 & F-250 THROUGH 1996 / 1997 F-250 OVER 8500 GVW, F350 THROUGH 1997 / 1999 to 2016 F-250 / F-350 & F-450 SUPERDUTY PICKUPS (Not Cab-On-Chassis)

1. On short bed trucks, attach the Driver's Side forward bracket on Row B to avoid interference with fuel lines.
2. On trucks with overload springs, switch position of long and short brackets.
3. The base rail location may need to be adjusted $\pm 1/2"$ to ensure frame brackets do not interfere with bed sills.

Only one of the two holes in the center of each of the base rails is necessary, check for obstructions before drilling.

NOTE: Some later models will require exchanging forward long brackets from front to rear and or repositioning forward brackets to Row B. This is to avoid brake cable hangers and overload springs. Shown here by dashed lines.

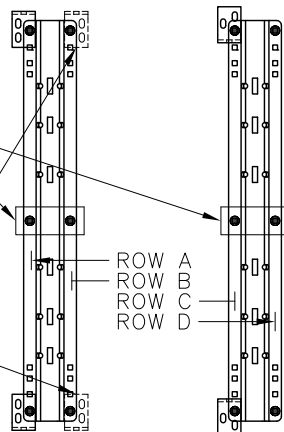

TOP VIEW

DISTANCE FROM EDGE OF RAIL TO END OF BED

LONG BED & SHORT BED: 32-1/2"

CAUTION:

Read pages 1-2 of these instructions before starting installation. Failure to do so could result in significant vehicle damage!

CAUTION:

Check for obstructions before drilling. Failure to do so could result in damaged fuel or brake lines, structural members, etc. B&W does its best to communicate tow vehicle manufacturer changes; however, it is ultimately the responsibility of the installer to prevent damage due to installation.

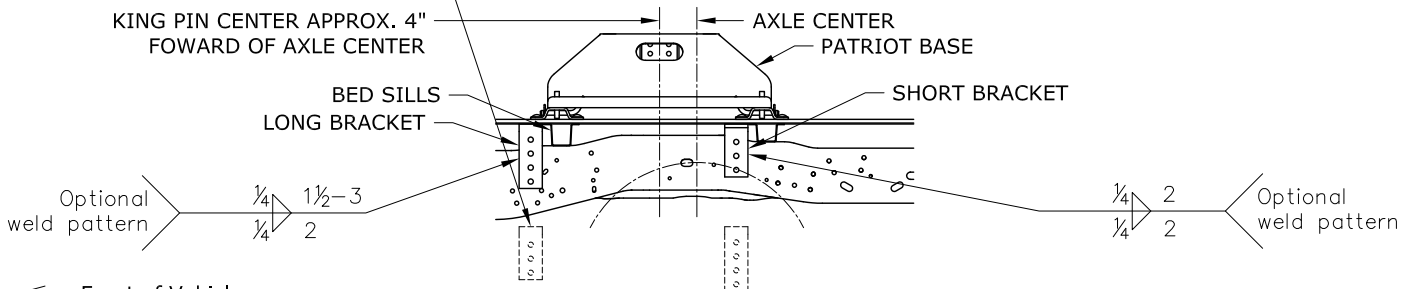

VIEW OF DRIVER SIDE (F350 SUPER DUTY LONG BED SHOWN)

FORD 1997 to 2003 F-150 & F-250 8500 GVW AND UNDER and 2004 Heritage Series Body Style

1. Long and Short Brackets on Driver's Side may need to be switched to avoid interference with exhaust hanger.
2. May need to move base rail location +/- 1/2" to ensure frame brackets do not interfere with bed sills.

Only one of the two holes in the center of each of the base rails is necessary, check for obstructions before drilling.

DISTANCE FROM EDGE OF RAIL TO END OF BED

LONG BED & SHORT BED: 29-1/4"

CAUTION:

Read pages 1-2 of these instructions before starting installation. Failure to do so could result in significant vehicle damage!

CAUTION:

Check for obstructions before drilling. Failure to do so could result in damaged fuel or brake lines, structural members, etc. B&W does its best to communicate tow vehicle manufacturer changes; however, it is ultimately the responsibility of the installer to prevent damage due to installation.

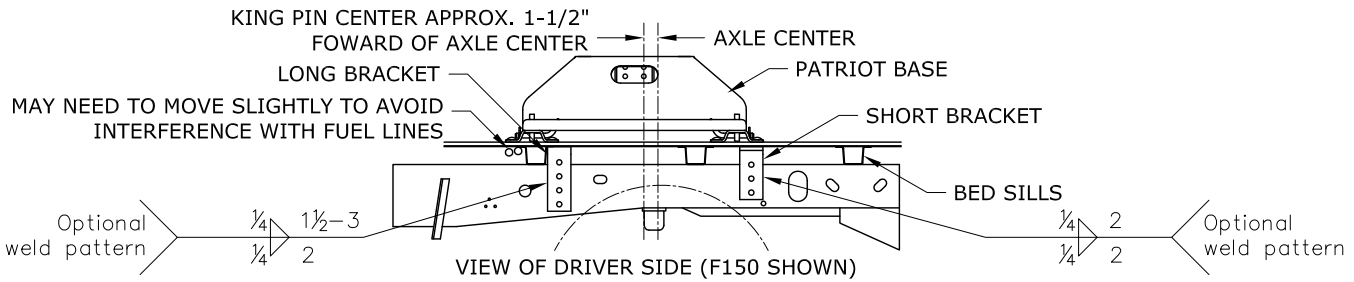
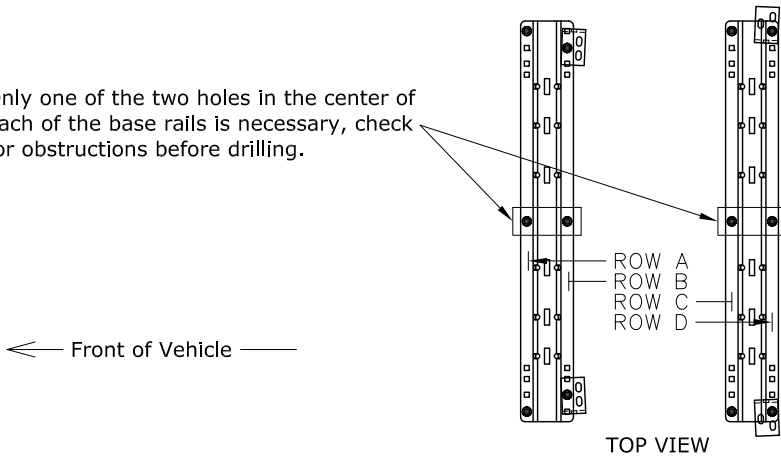

RAM 2013 Model Year 2500 HD without overload brackets

Before beginning, find the parallel rows of bed sill spot welds in bed of the truck. No drilling should be done in the 4" space between parallel rows of spot welds where the bed sill is located.

Only one of the two holes in the center of each of the base rails is necessary, check for obstructions before drilling.

DISTANCE FROM EDGE OF RAIL TO END OF BED

8' BED: 28-3/8"

5'8" & 6'6" BED: 26-3/8"

INSTALLATION NOTES:

- in "Row C" driver side position, drill through Bed Sill with 17/32" drill. Open up hole through truck bed only with 1" dia. drill. Drop tube spacer through hole in truckbed to avoid crushing Bed Sill when torquing 4-1/2" carriage bolt.
- Frame mounting bolts will need to be pulled through an access hole in the bottom of the frame with pull wires.
- Pull wires used on the forward bolts will need wire extensions.

Only the wall of the frame to which a bracket is mounted needs to be drilled. There is no need to drill though both sides.

The bolt locations in "Row B" need to be as close to the truck bed sill as possible. Variation in the bed placement may make installation of "Row C" brackets difficult if "Row B" brackets are too far from the bed sill. Check for clearance before drilling holes in frame and bed.

CAUTION:

Read pages 1-2 of these instructions before starting installation. Failure to do so could result in significant vehicle damage!

CAUTION:

Check for obstructions before drilling. Failure to do so could result in damaged fuel or brake lines, structural members, etc. B&W does its best to communicate tow vehicle manufacturer changes; however, it is ultimately the responsibility of the installer to prevent damage due to installation.

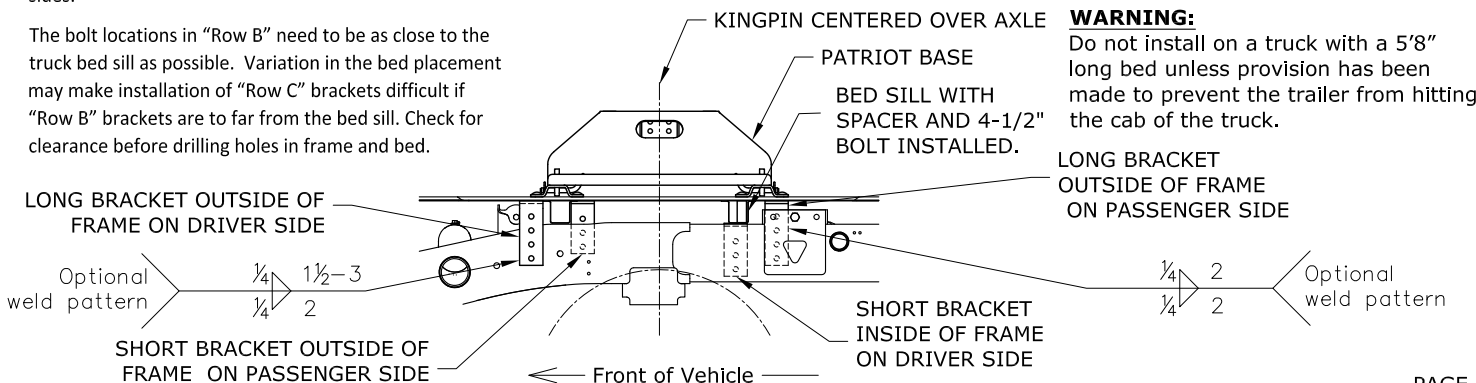
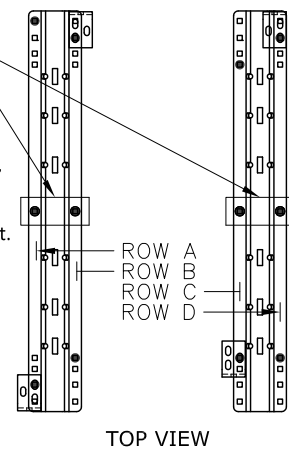

**DODGE 2002 THROUGH 2008 1500 / 2003 THROUGH 2012 2500 WITHOUT OVERLOAD BRACKETS
(2003 THROUGH 2012 2500 WITH OVERLOAD AND 3500 REQUIRE BRACKET KIT 3202)**

1. Use a tube spacer and 4 1/2" carriage bolt to attach rails through the rearward Bed Sill in Row C.
2. **Rib neck bolts will need to be pulled through access holes in frame with supplied pull wire (see below).
3. Do not drill thru both walls of frame. Drill only thru wall of frame to which a bracket is mounted.
4. It is very important that brackets in Row B are against rear side of Bed Sill as shown. Due to dimensional instability in Bed Sill placement with the Dodge truck, interference could result when drilling in Row C. Observe caution note below and double check all areas prior to drilling.
5. *Due to tubular frames having thinner walls than previous C channel frames, extra caution needs to be used when mounting with the optional welding.

Drill through Bed Sill with 17/32" drill. Open up hole through truck bed only with 1" dia. drill. Drop tube spacer through hole in truckbed to avoid crushing Bed Sill when torquing 4-1/2" carriage bolt.

Only one of the two holes in the center of each of the base rails is necessary, check for obstructions before drilling.

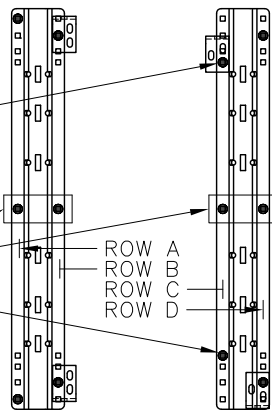

TOP VIEW

DISTANCE FROM EDGE OF RAIL TO END OF BED

LONG BED: 28-5/16"

SHORT BED: 26-5/16"

CAUTION:

Read pages 1-2 of these instructions before starting installation. Failure to do so could result in significant vehicle damage!

CAUTION:

Check for obstructions before drilling. Failure to do so could result in damaged fuel or brake lines, structural members, etc. B&W does its best to communicate tow vehicle manufacturer changes; however, it is ultimately the responsibility of the installer to prevent damage due to installation.

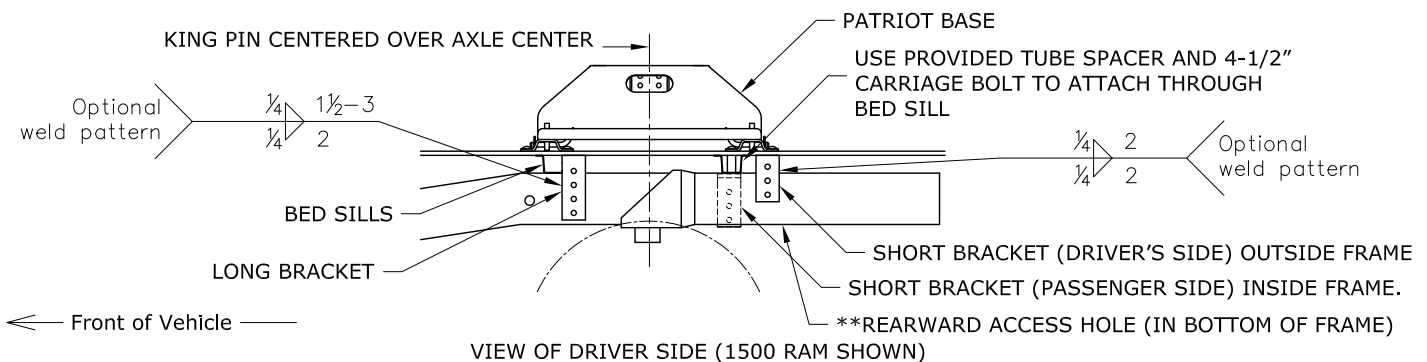

VIEW OF DRIVER SIDE (1500 RAM SHOWN)

DODGE 1994 to 2001 1500 / 1994 to 2002 2500/3500 (FULL SIZE, SHORT AND LONG BOX)

1. It is very important that brackets in Row B are against forward side of bed sill as shown below. Due to dimensional instability in bed sill placement with the Dodge truck, interference could result when drilling in Rows C or D. May need to move base rail location +/- 1/2" to ensure frame brackets do not interfere with bed sills.

Only one of the two holes in the center of each of the base rails is necessary, check for obstructions before drilling.

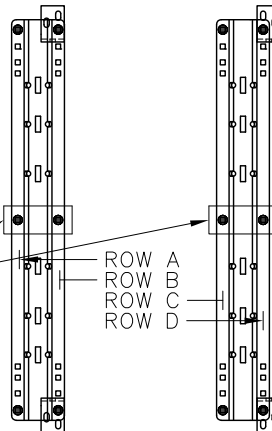

TOP VIEW

DISTANCE FROM EDGE OF RAIL TO END OF BED

LONG BED: 32-7/16"

SHORT BED: 28-7/16"

CAUTION:

Read pages 1-2 of these instructions before starting installation. Failure to do so could result in significant vehicle damage!

CAUTION:

Check for obstructions before drilling. Failure to do so could result in damaged fuel or brake lines, structural members, etc. B&W does its best to communicate tow vehicle manufacturer changes; however, it is ultimately the responsibility of the installer to prevent damage due to installation.

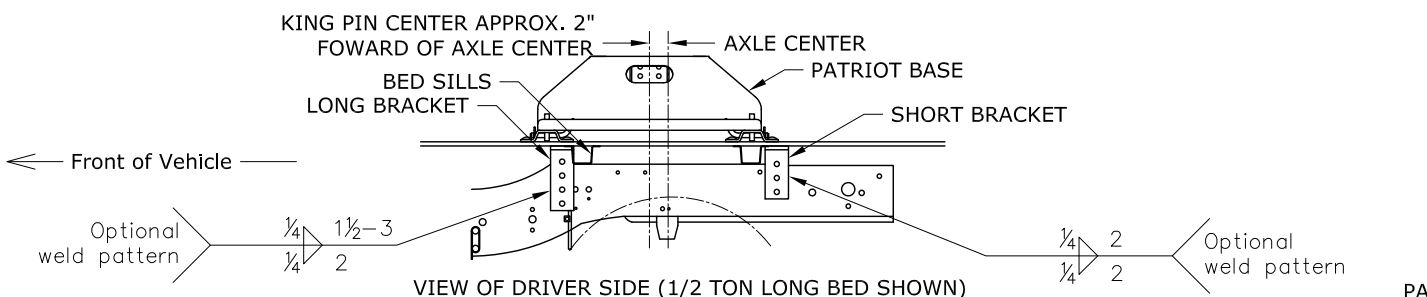

VIEW OF DRIVER SIDE (1/2 TON LONG BED SHOWN)

DODGE THROUGH 1993 (FULL SIZE)

1. May need to move base rail location +/- 1/2" to ensure frame brackets do not interfere with bed sills

Only one of the two holes in the center of each of the base rails is necessary, check for obstructions before drilling.

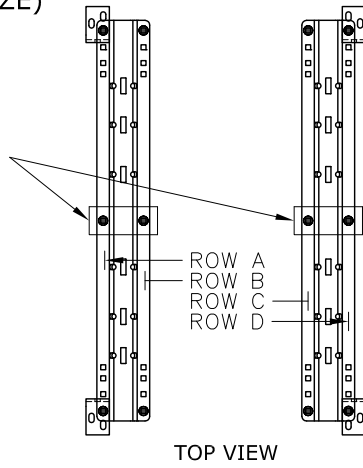

TOP VIEW

DISTANCE FROM EDGE OF RAIL TO END OF BED

LONG BED & SHORT BED: 29-5/8"

CAUTION:

Read pages 1-2 of these instructions before starting installation. Failure to do so could result in significant vehicle damage!

CAUTION:

Check for obstructions before drilling. Failure to do so could result in damaged fuel or brake lines, structural members, etc. B&W does its best to communicate tow vehicle manufacturer changes; however, it is ultimately the responsibility of the installer to prevent damage due to installation.

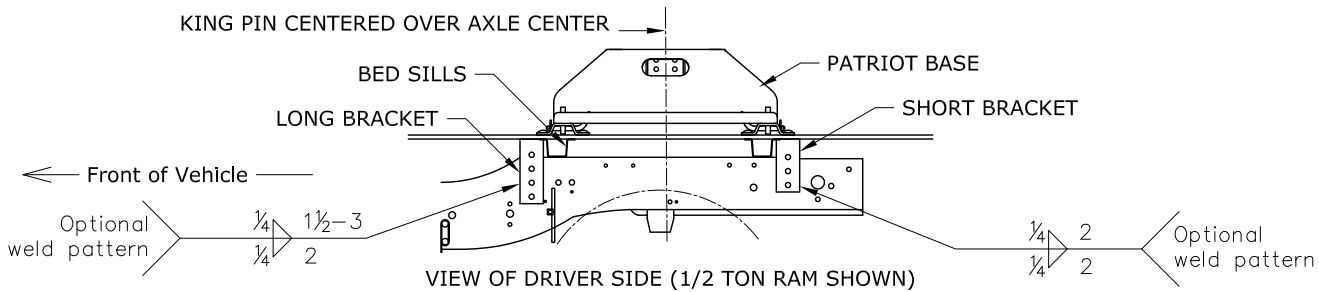

VIEW OF DRIVER SIDE (1/2 TON RAM SHOWN)

DODGE 1994 to 2004 DAKOTA

1. Before beginning, find the parallel rows of bed sill spot welds in bed of the truck. No drilling should be done in the 4" space between parallel rows of spot welds where the bed sill is located.
2. Cut 1" from top flange of brackets. Under bed, mount brackets with flanges facing out.
3. Put rear brackets on Row C for '97 to Present models. Put brackets on Row D for '96 and Earlier models.

Only one of the two holes in the center of each of the base rails is necessary, check for obstructions before drilling.

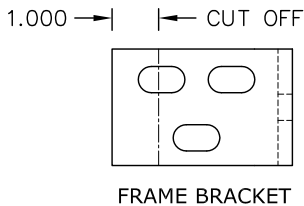

FRAME BRACKET

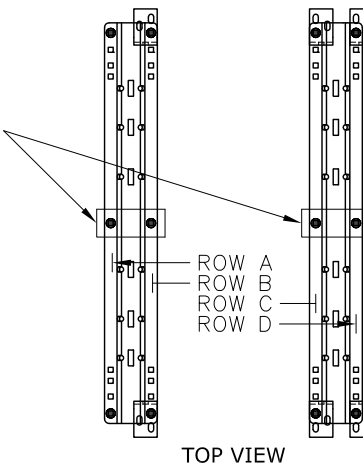

TOP VIEW

DISTANCE FROM EDGE OF RAIL TO END OF BED

LONG BED AND SHORT BED: 26"

CAUTION:

Read pages 1-2 of these instructions before starting installation. Failure to do so could result in significant vehicle damage!

CAUTION:

Check for obstructions before drilling. Failure to do so could result in damaged fuel or brake lines, structural members, etc. B&W does its best to communicate tow vehicle manufacturer changes; however, it is ultimately the responsibility of the installer to prevent damage due to installation.

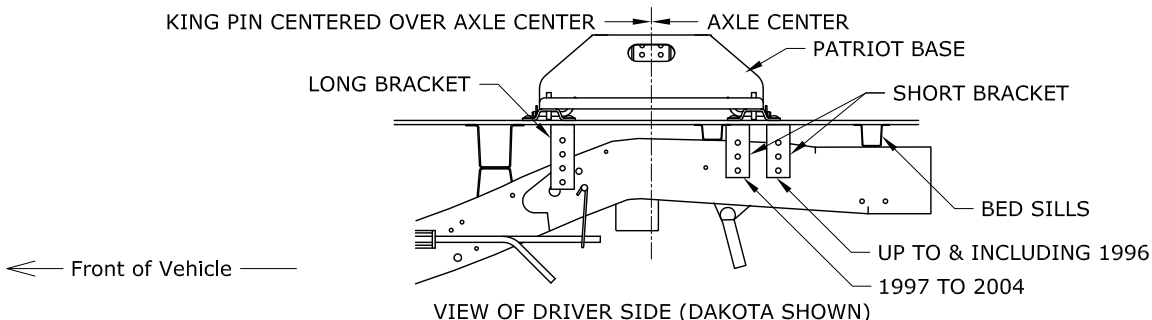

VIEW OF DRIVER SIDE (DAKOTA SHOWN)

Supplemental bracket kits.

NOTE: Truck installation which need additional hardware to allow the 3200 kit to be installed:

FORD 2004 to 2014 F-150, 5.5', 6', & 8' BEDS - Requires Bracket Kit [3201](#)

DODGE 2003 to 2012 2500 AND 3500 - Requires Bracket Kit [3202](#)

NISSAN TITAN 2004 TO 2015 - Requires Bracket Kit [3203](#)

2007 TO 2019 TOYOTA TUNDRA 6.5' & 8' BEDS - Requires Bracket Kit [3204](#)

2009 TO 2015 DODGE RAM 1500, INCLUDING CREWCAB - Requires Bracket Kit [3205](#)

TOYOTA TUNDRA 2000 to 2006 (STANDARD CAB LONG BOX ONLY) - Requires Bracket Kit [3206](#)